

**Division 1:**

# **General Conditions**

For

## **2025-1 CCMG PAVING PROGRAM**

---

OWNERS:

ELKHART COUNTY, INDIANA, ACTING THROUGH  
ITS BOARD OF COUNTY COMMISSIONERS  
ELKHART COUNTY HIGHWAY DEPARTMENT  
ENGINEERING SECTION  
610 STEURY AVENUE  
GOSHEN, IN 46528

---



Elkhart County Highway Department  
610 Steury Avenue, Goshen, Indiana 46528  
Phone: 574-534-9394 • Fax: 574-533-7103

## TABLE OF CONTENTS

DEFINITIONS	6
ARTICLE 1 - PRELIMINARY MATTERS	10
1.1 Delivery of Bonds	10
1.2 Copies of Documents	10
1.3 Contract Documents	10
1.4 Commencement of Contract Time; Notice to Proceed	10
1.5 Starting the Project	10
1.6 Before Starting Construction	10
1.7 Submission for Review	11
1.8 Delivery of Certificates	11
1.9 Subcontracts	11
1.10 Preconstruction Conference	11
1.11 Non-Discrimination	11
1.12 Insurance	12
1.13 Proof of Carriage Insurance	14
1.14 Performance and Payment Bond	14
ARTICLE 2 - CONTRACT DOCUMENTS: INTENT, AMENDING, REUSE	14
2.1 Intent	14
2.2 Amending and Supplementing Contract Documents:	15
ARTICLE 3 - AVAILABILITY OF LANDS; PHYSICAL CONDITIONS; REFERENCE POINTS	15
3.1 Availability of Lands	15
3.2 Physical Conditions - Underground Facilities	16
3.3 Not Shown or Indicated	16
3.4 Assignment of Contract	16
ARTICLE 4 - CONTRACTOR'S RESPONSIBILITIES	16
4.1 Supervision and Superintendence	16
4.2 Labor, Materials and Equipment	17
4.3 Substitutes or "Or-Equal" Items	17
4.4 Contractor Responsibility	19
4.5 Subcontractor Responsibility	19
4.6 Permits	19
4.7 Laws and Regulations	19
4.8 Taxes	19

4.9	Use of Premises	20
4.10	Record Documents	20
4.11	Safety and Protection	21
4.12	Emergencies	21
4.13	Shop Drawings and Samples	22
4.14	Continuing the Work	22
4.15	Indemnification:	23
4.16	Sanitation	23
4.17	Road Closing Requirements	24
ARTICLE 5 - OTHER WORK		26
5.1	Related Work at Site	26
ARTICLE 6 - OWNER'S RESPONSIBILITIES		26
6.1	Communication	26
6.2	Appointment of Engineer	26
6.3	Payment	26
6.4	Change Orders	26
6.5	Inspection	26
6.6	Service Termination	27
ARTICLE 7 - ENGINEER'S STATUS DURING CONSTRUCTION		27
7.1	Owner's Representative	27
7.2	Visits to Site	27
7.3	Project Representation	27
7.4	Clarifications and Interpretations	27
7.5	Authorized Variations in Work	27
7.6	Rejecting Defective Work	28
7.7	Decisions on Disputes	28
7.8	Limitations on Engineer's Responsibilities	28
ARTICLE 8 - CHANGES IN THE WORK		29
8.1	Work Modifications	29
8.2	Disagreement	29
8.3	Contract Price and Time	29
8.4	Change orders	30
8.5	Notification of Change	30
ARTICLE 9 - CHANGE OF CONTRACT PRICE		30

9.1	Change Order	30
9.2	Determination of Contract Price	30
9.3	Cost of the Work	31
ARTICLE 10 - CHANGE OF CONTRACT TIME		31
ARTICLE 11 - WARRANTY AND GUARANTEE; TESTS AND INSPECTIONS; CORRECTION, REMOVAL OR ACCEPTANCE OF DEFECTIVE WORK		32
11.1	Warranty and Guarantee	32
11.2	Access to Work	32
11.3	Tests and Inspections	32
11.4	Uncovering Work	33
11.5	Owner May Stop the Work	33
11.6	Correction or Removal of Defective Work	33
11.7	Three Years Correction Period	33
11.8	Maintenance Bond	33
11.9	Acceptance of Defective Work:	34
11.10	OWNER May Correct Defective Work:	34
ARTICLE 12 - PAYMENTS TO CONTRACTOR AND COMPLETION		34
12.1	Schedule of Values	34
12.2	Application for Progress Payment	34
12.3	Contractor's Warranty of Title	35
12.4	Review of Applications for Progress Payment	35
12.5	Substantial Completion	36
12.6	Partial Utilization	37
12.7	Final Inspection	38
12.8	Final Application for Payment	38
12.9	Final Payment and Acceptance	38
12.10	Contractor's Continuing Obligation	39
12.11	Waiver of Claims	39
ARTICLE 13 - SUSPENSION OF WORK AND TERMINATION		39
13.1	OWNER May Suspend Work	39
13.2	Conditions of Termination by Owner	39
13.3	Termination by Owner	40
13.4	Conditions of Termination by Contractor	41
ARTICLE 14 - MISCELLANEOUS		42
14.1	Giving Notice	42

14.2	Computation of Time	42
14.3	Bid Submission	42
	<b>BID FORM</b>	43
	<b>BID BOND</b>	45
	<b>CERTIFICATE AS TO CORPORATE PRINCIPAL</b>	48
	<b>PERFORMANCE AND PAYMENT BOND</b>	49
	<b>AGREEMENT</b>	55

## DEFINITIONS

The following terms, as used in these Contract Documents, are defined as follows:

"ADDENDA"	Written or graphic instruments issued prior to the opening of Bids, which clarify, correct, or change the bidding documents or Contract Documents.
"APPROVED"	The words "approved", "acceptable", "satisfactory", "in the judgment of", and words of like import, shall mean approval by, acceptable to, satisfactory to, or in the judgment of, the Engineer or Owner.
"BONDS"	Bid, Performance, Payment, or Maintenance Bonds, and other instruments of security collectively or individually as applicable.
"CHANGE ORDER"	A document recommended by ENGINEER, which is signed by CONTRACTOR and OWNER and authorizes an addition, deletion or revision in the Work, or an adjustment in the Contract Price or the Contract Time, issued on or after the Effective Date of the Agreement.
"CONTRACTOR"	The person, firm, or corporation to whom the enclosed contract is awarded by the Owner and who is subject to the terms hereof.
"COUNTY SPECIFICATIONS"	The current Elkhart County roads guidelines and standards for design and public improvements.
"DIRECTED"	The words "directed", "required", "permitted", "ordered", "designated", and words of like import shall imply the direction, requirement, permission, order of designation of the Engineer or Owner.
"ENGINEER"	The Elkhart County Highway Division, or, the Elkhart Co. Manager of Engineering, or duly authorized representative designated by the Owner.
"FIELD ORDER"	A written order issued by ENGINEER which orders minor changes in the Work in accordance with paragraph 7.5 but which does not involve a change in the Contract Price or the Contract Time.
"FINAL ACCEPTANCE"	The date when OWNER accepts ENGINEER'S recommendation of final payment.

"GENERAL REQUIREMENTS"	Sections of Division A of the Specifications.
"LAWS AND REGULATIONS; LAWS OR REGULATIONS"	Laws, rules, regulations, ordinances, codes and/or orders.
"MUTCD"	Manual of uniform traffic control devices.
"NOTICE TO PROCEED"	A written notice given by OWNER to CONTRACTOR (with a copy to ENGINEER) fixing the date on which the Contract Time will commence to run and on which CONTRACTOR shall start to perform CONTRACTOR'S obligations under the Contract Documents.
"OWNER"	The public body or authority, corporation, association, firm or person with whom CONTRACTOR has entered into the Agreement and for whom the Work is to be provided. This typically being Elkhart County, Indiana, acting through its Board of County Commissioners.
"PARTIAL UTILIZATION"	Placing a portion of the Work in service for the purpose for which it is intended (or a related purpose) before reaching Substantial Completion for all the Work.
"PROJECT"	The total construction of which the Work to be provided under the Contract Documents may be the whole or a part as indicated elsewhere in the Contract Documents.
"RESIDENT PROJECT REPRESENTATIVE"	The authorized representative of ENGINEER who is assigned to the site or any part thereof
"SHOP DRAWINGS"	All drawings, diagrams, illustrations, schedules and other data which are specifically prepared by or for CONTRACTOR to illustrate some portion of the Work and all illustrations, brochures, standard schedules, performance charts, instructions, diagrams and other information prepared by a Supplier and submitted by CONTRACTOR to illustrate material or equipment for some portion of the Work.
"SPECIFICATIONS"	Those portions of the Contract Documents consisting of written technical descriptions of materials, equipment, construction systems, standards and workmanship as applied to the Work and certain administrative details applicable thereto.

"STANDARD DETAILS"	The current INDOT standard sheets with standard details.
"STANDARD SPECIFICATIONS"	The latest edition of the Indiana Department of Transportation Standard Specifications and current supplemental Technical Specifications.
"STOP ORDER or STOP WORK ORDER"	Written order from OWNER or ENGINEER to stop all work covered by the Contract Documents.
"SUBCONTRACTOR"	An individual, firm or corporation having a direct contract with CONTRACTOR or with any other Subcontractor for the performance of a part of the Work at the site.
"SUBSTANTIAL COMPLETION"	See Paragraph 12.5 of these General Conditions.
"SUPPLEMENTARY CONDITIONS"	The part of the Contract Documents which amends or supplements these General Conditions.
"SUBSTANTIAL COMPLETION"	See Paragraph 12.5 of these General Conditions.
"SURETY"	Financial guarantee that insures the CONTRACTOR'S obligation.
"UNDERGROUND FACILITIES"	All pipelines, conduits, ducts, cables, wires, manholes, vaults, tanks, tunnels or other such facilities or attachments. In addition, any encasement containing such facilities that have been installed underground to furnish any of the following services or materials; electricity, gases, steam, liquid petroleum products, telephone or other communication means, cable television, sewage and drainage removal, traffic or other control systems or water.
"UNIT PRICE WORK"	Work to be paid for on the basis of unit prices.
"WORK"	Work to be done under this Contract at the site of the improvement.
"WORK DIRECTIVE CHANGE"	A written directive to CONTRACTOR, issued on or after the Effective Date of the Agreement and signed by OWNER and recommended by ENGINEER, ordering an addition, deletion or revision in the Work, or responding to differing or unforeseen physical conditions under which the Work is to be performed.



"WRITTEN AMENDMENT"

A written amendment of the Contract Documents, signed by OWNER and CONTRACTOR on or after the Effective Date of the Agreement and normally dealing with the non-engineering or non-technical rather than strictly Work-related aspects of the Contract Documents

**ARTICLE 1 - PRELIMINARY MATTERS****1.1 Delivery of Bonds**

When CONTRACTOR delivers the executed Agreements to OWNER, CONTRACTOR shall also deliver to OWNER such Bonds as called for in the Contract Documents.

**1.2 Copies of Documents**

OWNER shall furnish to CONTRACTOR up to three (3) copies (unless otherwise specified in the Supplementary Conditions) of the Contract Documents as are reasonably necessary for the execution of the Work. Additional copies will be furnished, upon request, at the cost of reproduction.

**1.3 Contract Documents**

These Contract Documents are complementary and what is called for in one shall be as binding as if called for in all. The intention of these Contract Documents is to include in the Contract Price the costs of all labor and materials, water, fuel, tools, plant, equipment, light, transportation, taxes, bonds, and all other expense and profit as may be necessary for the proper and complete execution of the work.

**1.4 Commencement of Contract Time; Notice to Proceed**

The Contract Time will commence when the Contractor receives the Notice to Proceed from the Engineer. CONTRACTOR shall not be paid for any work performed prior to receiving the Notice to Proceed from the Engineer.

**1.5 Starting the Project**

CONTRACTOR shall start to perform the Work on the date when the Contract Time commences to run, but no Work shall be done at the site prior to the date on which the Contract Time commences to run unless such work is specifically approved by the owner/engineer.

**1.6 Before Starting Construction**

Before undertaking each part of the Work, CONTRACTOR shall carefully study and compare the Contract Documents and check and verify pertinent figures shown thereon and all applicable field measurements. CONTRACTOR shall promptly report in writing to ENGINEER any conflict, error or discrepancy which CONTRACTOR may discover and shall obtain a written interpretation or clarification from ENGINEER before proceeding with any Work affected thereby; however, CONTRACTOR shall not be liable to OWNER or ENGINEER for failure to report any conflict, error or discrepancy in the Contract Documents, unless CONTRACTOR had actual knowledge thereof or should reasonably have known thereof.

**1.7 Submission for Review**

Within ten (10) days after the Effective Date of the Agreement (unless otherwise specified in the General Requirements), CONTRACTOR shall submit to ENGINEER for review:

1.7.1 An estimated progress schedule indicating the starting and completion dates of the various stages of the Work; and

1.7.2 A preliminary schedule of Shop Drawings and/or sample submissions.

1.7.3 CONTRACTOR shall provide an updated progress schedule at all scheduled progress meetings.

**1.8 Delivery of Certificates**

Before any Work at the site is started, CONTRACTOR shall deliver to OWNER, with a copy to ENGINEER, certificates (and other evidence of insurance requested by OWNER) which CONTRACTOR is required to purchase and maintain.

**1.9 Subcontracts**

The Contractor shall not execute an Agreement with any Subcontractor or permit any Subcontractor to perform any work in this Contract until he has received written approval of such Subcontractor from the Owner or Owner's appointed designee.

**1.10 Preconstruction Conference**

Following the Effective Date of the Agreement, but before CONTRACTOR starts the Work at the site, a conference attended by CONTRACTOR, ENGINEER and others, as appropriate, will be held to discuss the schedules referred to in paragraph 1.7, as well as the Subcontractors proposed by Contractor for certain portions of the work, to discuss procedures for handling Shop Drawings and other submittals and for processing Applications for Payment, and to establish a working understanding among the parties as to the Work.

**1.11 Non-Discrimination**

In compliance with the Acts of Indiana General Assembly, 1933, Chapter 270, the Contractor hereby agrees:

1.11.1 That in the hiring of employees for the performance of work under this Contract or any Subcontract hereunder, no Contractor, Subcontractor, nor any person acting on behalf of such Contractor or Subcontractor shall, by reason of race or color, discriminate against any citizen qualified to do work to which the employment relates;

1.11.2 That no Contractor, Subcontractor, nor any person on his behalf shall, in any manner, discriminate against or intimidate any employee hired for the performance of work under this Contract on account of race or color;

1.11.3 That there may be deducted from the amount payable to the Contractor by the Owner under this contract, a penalty of Five Dollars (\$5.00) for each person for each calendar day during which such person was discriminated against or intimidated in violation of the provisions of this Contract; and

1.11.4 That this Contract may be canceled or terminated by the Owner, and all money due or to become due hereunder may be forfeited for a second or any subsequent violation of the terms or conditions of this section of the Contract.

1.12 Insurance

1.12.1 Contractor's Liability Insurance:

a) The Contractor shall maintain such insurance as well as protect himself from claims under Workmen's Compensation Acts and other employee benefit acts; from claims for damages because of bodily injury, including death, to his employees and all others; and from claims for damages to property, any or all of which may arise out of or result from the Contractor's operation under the Contract, whether such operations be by himself or by any subcontractor, or anyone directly or indirectly employed by either of them. This insurance shall be written for not less than any limits of liability specified herein and shall name Elkhart County as an additional insured.

1.12.2 Contractor's Insurance:

The types and minimum amount of insurance to be provided for by the Contractor shall be as follows:

a) Workmen's Compensation and Occupational Disease Insurance

The Contractor shall provide Workmen's Compensation and Occupational Disease Insurance as required by law. Such policy shall specifically include coverage for the State of Indiana, and such adjoining states as required by the Contractor's operations.

b) Employer's Liability Insurance

The Contractor shall provide Employer's Liability with a minimum coverage of \$1,000,000.

## c) Comprehensive General Liability Insurance

The Contractor shall maintain a Comprehensive General Liability form of Insurance with bodily injury of not less than \$1,000,000 for any one (1) occurrence, and \$2,000,000 aggregate. The insurance policy shall include the following:

1. Premises Operations: The policy shall include coverage for the following special hazards when applicable to the project:

i) Property damage arising out of blasting or explosion.

ii) Property damage arising out of collapse of or structural injury to any building or structure due to grading of land, excavation, borrowing, filling, backfilling, tunneling, pile driving, cofferdam work or caisson work or to moving, shoring, underpinning, raising, or demolition of any building or structure or rebuilding of any structural support thereof.

iii) Injury to or destruction of wires, conduits, pipes, mains, sewers, and other similar property of any apparatus in connection therewith below the surface of ground, if caused by use of mechanical equipment.

2. Contractual (Broad Form Indemnification): The Contractor agrees to indemnify and save harmless the Owner and the Engineer, their agents and employees, from and against all loss or expense (including costs and attorneys' fees) by reason of liability imposed by law upon the Owner or the Engineer for damages because of bodily injury, including death, at any time resulting there from, sustained by any person or persons or an account of damage to property is due or claimed to be due to negligence of the Contractor, his Subcontractors, employees or agents.

3. Contractor's Protective: The Contractor shall maintain this type of coverage on a "Blanket" basis to cover the operations of any subcontractors.

## d) Automobile Liability Insurance

The Contractor shall maintain Comprehensive Automobile Liability Insurance with bodily injury liability limits of not less than \$1,000,000 for one (1) occurrence and \$2,000,000 aggregate. This coverage may be provided either as a separate policy or as part of the Comprehensive General Liability Policy described previously. The automobile insurance must include coverage for all owned, non-owned and hired vehicles.

- e) Furnish Indiana State Forms No. 19 (Workmen's Compensation) and No.105 (Occupational Disease Act).
- f) Umbrella Policy Insurance

The Contractor shall maintain a minimum \$3,000,000 Umbrella Policy in addition to their primary insurance.

1.13 Proof of Carriage Insurance

1.13.1 Contractor shall not commence work until he has obtained all insurance specified herein, has filed with the Owner one (1) copy of Certificate of Insurance, and such insurance has been approved by the Owner.

1.13.2 Should any Coverage approach expiration during the Contract period, it shall be renewed prior to its expiration, and certificate again filed with the Owner.

1.13.3 If any of such policies are canceled or are changed so as to reduce the coverage evidenced by the Certificate, at least ten (10) days prior written notice by registered mail of such cancellation or change shall be sent to the Owner.

1.13.4 All insurance provided for under this Section shall be written by Insurance Companies licensed to do business in Indiana and Countersigned by resident Indiana agent. The insurance company shall file with the Owner, one (1) copy of Affirmation of Authority, on the form furnished by the Engineer, as verification of the resident agent.

1.13.5 All insurance shall be maintained in full force and effect until the Contract has been fully and completely performed.

1.14 Performance and Payment Bond

The Contractor shall furnish a Performance and Payment Bond (form attached) equal to one hundred percent (100%) of the Contract Price.

ARTICLE 2 - CONTRACT DOCUMENTS: INTENT, AMENDING, REUSE

2.1 Intent

The Contract Documents comprise the entire agreement between OWNER and CONTRACTOR concerning the Work. The Contract Documents are complementary; what is called for by one is as binding as if called for by all. The Contract Documents will be construed in accordance with the law of the place of the Project.

2.1.1 It is the intent of the Contract Documents to describe a functionally complete

Project (or part thereof) to be constructed in accordance with the Contract Documents. Any Work, materials or equipment that may reasonably be inferred from the Contract Documents as being required to produce the intended result will be supplied whether or not specifically called for.

2.1.2 If during the performance of the Work, CONTRACTOR finds a conflict, error or discrepancy in the Contract Documents, CONTRACTOR shall so report to ENGINEER in writing at once and before proceeding with the Work affected thereby shall obtain a written interpretation or clarification from ENGINEER; however, CONTRACTOR shall not be liable to OWNER or ENGINEER for failure to report any conflict, error or discrepancy in the Contract Documents unless CONTRACTOR had actual knowledge thereof or should reasonably have known thereof.

**2.2 Amending and Supplementing Contract Documents:**

The Contract Documents may be amended to provide for additions, deletions and revisions in the Work or to modify the terms and conditions thereof in one or more of the following ways:

- 2.2.1 A formal Written Amendment,
- 2.2.2 A Change Order, or
- 2.2.3 A Work Directive Change (pursuant to paragraph 8.1).

In addition, the requirements of the Contract Documents may be supplemented and minor variations and deviations in the Work may be authorized, in one or more of the following ways:

- 2.2.4 A Field Order,
- 2.2.5 ENGINEER's approval of a Shop Drawing or sample, or
- 2.2.6 ENGINEER's written interpretation or clarification.

**ARTICLE 3 - AVAILABILITY OF LANDS; PHYSICAL CONDITIONS; REFERENCE POINTS**

**3.1 Availability of Lands**

OWNER shall indicate, as shown in the Contract Documents, the lands upon which the Work is to be performed, rights-of-way and easements for access thereto, and such other lands which are designated for the use of CONTRACTOR. Easements for permanent structures or permanent changes in existing facilities will be obtained and paid for by OWNER, unless otherwise provided in the Contract Documents. If CONTRACTOR believes that any delay in OWNER's furnishing these lands, rights-of-way or easements

entitles CONTRACTOR to an extension of the Contract Time, CONTRACTOR may make a claim for an extension of Contract Time.

**3.2 Physical Conditions - Underground Facilities**

The information and data shown or indicated in the Contract Documents with respect to existing Underground Facilities at or contiguous to the site is based on information and data furnished to OWNER or ENGINEER by the owners of such Underground Facilities or by others. Unless it is otherwise expressly provided in the Supplementary Conditions:

3.2.1 OWNER and ENGINEER shall not be responsible for the accuracy or completeness of any such information or data; and,

3.2.2 CONTRACTOR shall have full responsibility for reviewing and checking all such information and data, for locating all Underground Facilities shown or indicated in the Contract Documents, for coordination of the Work with the owners of such Underground Facilities during construction, for the safety and protection thereof, and repairing any damage thereto resulting from the Work, the cost of all of which will be considered as having been included in the Contract Price.

**3.3 Not Shown or Indicated**

If an Underground Facility is uncovered or revealed at or contiguous to the site which was not shown or indicated in the Contract Documents and which CONTRACTOR could not reasonably have been expected to be aware of, CONTRACTOR shall, promptly after becoming aware thereof and before performing any Work affected thereby (except in an emergency) as permitted by paragraph 4.2.1, identify the owner of such Underground Facility and give written notice thereof to that owner and to OWNER and ENGINEER. ENGINEER will promptly review the Underground Facility to determine the extent to which the Contract Documents should be modified to reflect and document the consequences of the existence of the Underground Facility, and the Contract Documents will be amended or supplemented to the extent necessary. During such time, CONTRACTOR shall be responsible for the safety and protection of such Underground Facility. CONTRACTOR shall be allowed an increase in the Contract Price or an extension of the Contract Time, or both, to the extent that they are attributable to the existence of any Underground Facility.

**3.4 Assignment of Contract**

The Contractor shall not assign this Contract or any part hereof without prior consent of the Owner.

**ARTICLE 4 - CONTRACTOR'S RESPONSIBILITIES**

**4.1 Supervision and Superintendence**



4.1.1 CONTRACTOR shall supervise and direct the Work competently and efficiently, devoting such attention thereto and applying such skills and expertise as may be necessary to perform the Work in accordance with the Contract Documents. CONTRACTOR shall be solely responsible for the means, methods, techniques, sequences and procedures of construction, but CONTRACTOR shall not be responsible for the negligence of others in the design or selection of a specific means, method, technique, sequence or procedure of construction which is indicated in and required by the Contract Documents. CONTRACTOR shall be responsible to see that the finished Work complies accurately with the Contract Documents.

4.1.2 CONTRACTOR shall keep on the Work at all times during its progress a competent resident superintendent, who shall not be replaced without written notice to OWNER and ENGINEER except under extraordinary circumstances. The superintendent will be CONTRACTOR's representative at the site and shall have authority to act on behalf of CONTRACTOR. All communications given to the superintendent shall be as binding as if given to CONTRACTOR.

#### 4.2 Labor, Materials and Equipment

4.2.1 CONTRACTOR shall provide competent, suitably qualified personnel to survey and lay out the Work and perform construction as required by the Contract Documents. CONTRACTOR shall at all times maintain good discipline and order at the site, particularly in connection with the safety or protection of persons or the Work or property at the site or adjacent thereto, and except as otherwise indicated in the Contract Documents.

4.2.2 Unless otherwise specified in the General Conditions, CONTRACTOR shall furnish and assume full responsibility for all materials, equipment, labor, transportation, construction equipment and machinery, tools, appliances, fuel, power, light, heat, telephone, water, sanitary facilities, temporary facilities and all other facilities and incidentals necessary for the furnishing, performance, testing, start-up and completion of the Work.

4.2.3 All materials and equipment shall be of good quality and new, except as otherwise provided in the Contract Documents. If required by ENGINEER, CONTRACTOR shall furnish satisfactory evidence (including reports of required tests) as to the kind and quality of materials and equipment. All materials and equipment shall be applied, installed, connected, erected, used, cleaned and conditioned in accordance with the instructions of the applicable Supplier except as otherwise provided in the Contract Documents.

#### 4.3 Substitutes or "Or-Equal" Items

4.3.1 Whenever materials or equipment are specified or described in the Contract

---

Documents by using the name of a proprietary item or the name of a particular Supplier the naming of the item is intended to establish the type, function and quality required. Unless the name is followed by words indicating that no substitution is permitted, materials or equipment of other Suppliers may be accepted by ENGINEER if sufficient information is submitted by CONTRACTOR to allow ENGINEER to determine that the material or equipment proposed is equivalent or equal to that named. The procedure for review by ENGINEER will include the following as supplemented in the General Conditions. Requests for review of substitute items of material and equipment will not be accepted by ENGINEER from anyone other than CONTRACTOR. If CONTRACTOR wishes to furnish or use a substitute item of material or equipment, CONTRACTOR shall make written application to ENGINEER for acceptance thereof, certifying that the proposed substitute will perform adequately the functions and achieve the results called for by the general design, be similar and of equal substance to that specified and be suited to the same use as that specified. The application will state that the evaluation and acceptance of the proposed substitute will not prejudice CONTRACTOR's achievement of Substantial Completion on time, whether or not acceptance of the substitute for use in the Work will require a change in any of the Contract Documents. All variations of the proposed substitute from that specified will be identified in the application and available maintenance, repair and replacement service will be indicated. The application will also contain an itemized estimate of all costs that will result directly or indirectly from acceptance of such substitute, including costs of redesign and claims of other contractors affected by the resulting change, all of which shall be considered by ENGINEER in evaluating the proposed substitute. ENGINEER may require CONTRACTOR to furnish at CONTRACTOR's expense additional data about the proposed substitute.

4.3.2 If a specific means, method, technique, sequence or procedure of construction is indicated in or required by the Contract Documents, CONTRACTOR may furnish or utilize a substitute means, method, sequence, technique or procedure of construction acceptable to ENGINEER, if CONTRACTOR submits sufficient information to allow ENGINEER to determine that the substitute proposed is equivalent to that indicated or required by the Contract Documents.

4.3.3 ENGINEER will be allowed a reasonable time within which to evaluate each proposed substitute. ENGINEER will be the sole judge of acceptability, and no substitute will be ordered, installed or utilized without ENGINEER's prior written acceptance which will be evidenced by either a Change Order or an approved Shop Drawing. OWNER may require CONTRACTOR to furnish at CONTRACTOR's expense a special performance guarantee or other surety with respect to any substitute. ENGINEER will record time required by ENGINEER and ENGINEER's consultants in evaluating substitutions proposed by CONTRACTOR and in making changes in the Contract Documents occasioned thereby. Whether or not ENGINEER accepts a proposed substitute, CONTRACTOR shall reimburse OWNER for the charges of ENGINEER and ENGINEER's consultants for evaluating each proposed substitute.

#### 4.4 Contractor Responsibility

CONTRACTOR shall be fully responsible to OWNER and ENGINEER for all acts and omissions of the Subcontractor, Suppliers and other persons and organizations performing or furnishing any of the Work under a direct or indirect contract with CONTRACTOR just as CONTRACTOR is responsible for CONTRACTOR's own acts and omissions. Nothing in the Contract Documents shall create any contractual relationship between OWNER or ENGINEER and any such Subcontractor, Supplier or other person or organization, nor shall it create any obligation on the part of OWNER or ENGINEER to pay or to see to the payment of any monies due any such Subcontractor, Supplier or other person or organization except as may otherwise be required by Laws and Regulations.

#### 4.5 Subcontractor Responsibility

All Work performed for CONTRACTOR by a Subcontractor will be pursuant to an appropriate agreement between CONTRACTOR and the Subcontractor which specifically binds the Subcontractor to the applicable terms and conditions of the Contract Documents for the benefit of OWNER and ENGINEER.

#### 4.6 Permits

Unless otherwise provided in the General Conditions, CONTRACTOR shall obtain and pay for all construction permits and licenses.

#### 4.7 Laws and Regulations

4.7.1 CONTRACTOR shall give all notices and comply with all Laws and Regulations applicable to furnishing and performance of the Work. Except where otherwise expressly required by applicable Laws and Regulations, neither OWNER nor ENGINEER shall be responsible for monitoring CONTRACTOR's compliance with any Laws or Regulations.

4.7.2 If CONTRACTOR observes that the Specifications or Drawings are at variance with any Laws or Regulations, CONTRACTOR shall give ENGINEER prompt written notice thereof, and any necessary changes will be authorized by one of the methods indicated in paragraph 2.2. If CONTRACTOR performs any Work knowing or having reason to know that it is contrary to such Laws or Regulations, and without such notice to ENGINEER, CONTRACTOR shall bear all costs arising therefrom; however, it shall not be CONTRACTOR's primary responsibility to make certain that the Specifications and Drawings are in accordance with such Laws and Regulations.

#### 4.8 Taxes

CONTRACTOR shall pay all sales, consumer, use and other similar taxes required to be

paid by CONTRACTOR in accordance with the Laws and Regulations of the place of the Project which are applicable during the performance of the Work.

#### 4.9 Use of Premises

4.9.1 CONTRACTOR shall confine construction equipment, the storage of materials and equipment and the operations of workers to the Project site and land and areas identified in and permitted by the Contract Documents and other land and areas permitted by Laws and Regulations, rights-of-way, permits and easements, and shall not unreasonably encumber the premises with construction equipment or other materials or equipment. CONTRACTOR shall assume full responsibility for any damage to any such land or area, or to the owner or occupant thereof or of any land or areas contiguous thereto, resulting from the performance of the Work. Should any claim be made against OWNER or ENGINEER by any such owner or occupant because of the performance of the Work, CONTRACTOR shall promptly attempt to settle with such other party by agreement or otherwise resolve the claim by arbitration or at law. CONTRACTOR shall, to the fullest extent permitted by Laws and Regulations, indemnify and hold OWNER and ENGINEER harmless from and against all claims, damages, losses and expenses (including, but not limited to, fees of engineers, architects, attorneys and other professionals and court and arbitration costs) arising directly, indirectly or consequentially out of any action, legal or equitable, brought by any such other party against OWNER or ENGINEER to the extent based on a claim arising out of CONTRACTOR's performance of the Work.

4.9.2 During the progress of the Work, CONTRACTOR shall keep the premises free from accumulations of waste materials, rubbish and other debris resulting from the Work. At the completion of the Work CONTRACTOR shall remove all waste materials, rubbish and debris from and about the premises as well as all tools, appliances, construction equipment and machinery, and surplus materials, and shall leave the site clean and ready for occupancy by OWNER. CONTRACTOR shall restore to original condition all property not designated for alteration by the Contract Documents.

4.9.3 CONTRACTOR shall not load nor permit any part of any structure to be loaded in any manner that will endanger the structure, nor shall CONTRACTOR subject any part of the Work or adjacent property to stresses or pressures that will endanger it.

#### 4.10 Record Documents

CONTRACTOR shall maintain in a safe place at the site one (1) record copy of all Drawings, Specifications, Addenda, Written Amendments, Change Orders, Work Directive Changes, Field Orders and written interpretations and clarifications issued in good order and annotated to show all changes made during construction. These record documents together with all approved samples and a counterpart of all approved Shop Drawings will be available to ENGINEER for reference. Upon completion of the Work,

these record documents, samples and Shop Drawings will be delivered to ENGINEER for OWNER.

#### 4.11 Safety and Protection

4.11.1 CONTRACTOR shall be responsible for initiating, maintaining and supervising all safety precautions and programs in connection with the Work. CONTRACTOR shall take all necessary precautions for the safety of, and shall provide the necessary protection to prevent damage, injury or loss to:

- a) All employees on the Work and other persons and organizations who may be affected thereby;
- b) All the Work and materials and equipment to be incorporated therein, whether in storage on or off the site; and
- c) Other property at the site or adjacent thereto, including trees, shrubs, lawns, walks, pavements, roadways, structures, utilities and Underground Facilities not designated for removal, relocation or replacement in the course of construction.

4.11.2 CONTRACTOR shall comply with all applicable Laws and Regulations of any public body having jurisdiction for the safety of persons or property or to protect them from damage, injury or loss; and shall erect and maintain all necessary safeguards for such safety and protection. CONTRACTOR shall notify owners of adjacent property and of Underground Facilities and utility owners when prosecution of the Work may affect them, and shall cooperate with them in the protection, removal, relocation and replacement of their property. All damage, injury or loss to any property referred to in paragraph 4.11.1(b) or 4.11.1(c) caused, directly or indirectly, in whole or in part, by CONTRACTOR, any Subcontractor, Supplier or any other person or organization directly or indirectly employed by any of them to perform or furnish any of the Work or anyone for whose acts any of them may be liable, shall be remedied by CONTRACTOR.

4.11.3 CONTRACTOR shall designate a responsible representative at the site whose duty shall be the prevention of accidents. This person shall be CONTRACTOR's superintendent unless otherwise designated in writing by CONTRACTOR to OWNER.

#### 4.12 Emergencies

In emergencies affecting the safety or protection of persons or the Work or property at the site or adjacent thereto, CONTRACTOR, without special instruction or authorization from ENGINEER or OWNER, is obligated to act to prevent threatened damage, injury or loss. CONTRACTOR shall give ENGINEER prompt written notice if CONTRACTOR believes that any significant changes in the Work or variations from the Contract Documents have been caused thereby. If ENGINEER determines that a change in the

Contract Documents is required because of the action taken in response to an emergency, a Work Directive Change or Change Order will be issued to document the consequences of the changes or variations.

#### 4.13 Shop Drawings and Samples

4.13.1 After checking and verifying all field measurements and after complying with applicable procedures specified in the General Conditions, CONTRACTOR shall submit to ENGINEER for review and approval three (3) copies of all Shop Drawings. All submissions will be identified as ENGINEER may require. The data shown on the Shop Drawings will be complete with respect to quantities, dimensions, specified performance and design criteria, materials and similar data to enable ENGINEER to review the information as required.

4.13.2 CONTRACTOR shall also submit to ENGINEER for review and approval with such promptness as to cause no delay in Work, all samples required by the Contract Documents.

4.13.3 At the time of each submission, CONTRACTOR shall give ENGINEER specific written notice of each variation that the Shop Drawings or samples may have from the requirements of the Contract Documents, and, in addition, shall cause a specific notation to be made on each Shop Drawing submitted to ENGINEER for review and approval of each such variation.

4.13.4 ENGINEER will review and approve with reasonable promptness Shop Drawings and samples, but ENGINEER's review and approval will be only for conformance with the design concept of the Project and for compliance with the information given in the Contract Documents and shall not extend to means, methods, techniques, sequences or procedures of construction.

4.13.5 ENGINEER's review and approval of Shop Drawings or samples shall not relieve CONTRACTOR from responsibility for any variation from the requirements of the Contract Documents unless CONTRACTOR has in writing called ENGINEER's attention to each such variation at the time of submission.

4.13.6 Where a Shop Drawing or sample is required by the Specifications, any related Work performed prior to ENGINEER's review and approval of the pertinent submission will be the sole expense and responsibility of CONTRACTOR.

#### 4.14 Continuing the Work

CONTRACTOR shall carry on the Work and adhere to the progress schedule during all disputes or disagreements with OWNER. No Work shall be delayed or postponed pending resolution of any disputes or disagreements, except as permitted by paragraph 13.4 or as CONTRACTOR and OWNER may otherwise agree in writing.

**4.15 Indemnification:**

To the fullest extent permitted by Laws and Regulations CONTRACTOR shall indemnify and hold harmless OWNER and ENGINEER and their consultants, agents and employees from and against all claims, damages, losses, and expenses, direct, indirect or consequential (including but not limited to fees and charges of engineer, architects, attorneys and other professionals and court and arbitration costs) arising out of or resulting from the performance of the Work, provided that any such claim, damage, loss or expense:

4.15.1 (a) is attributable to bodily injury, sickness, disease or death, or to injury to or destruction of tangible property (other than the Work itself) including the loss of use resulting there from and (b) is caused in whole or in part by any negligent act or omission of CONTRACTOR, any Subcontractor, any person or organization directly or indirectly employed by any of them to perform or furnish any of the Work or anyone for whose acts any of them may be liable, regardless of whether or not it is caused in part by a party indemnified hereunder or arises by or is imposed by Law and Regulations regardless of the negligence of any such party.

4.15.2 In any and all claims against OWNER or ENGINEER or any of their consultants, agents or employees by any employee of CONTRACTOR, any Subcontractor, any person or organization directly or indirectly employed by any of them to perform or furnish any of the Work or anyone for whose acts any of them may be liable, the indemnification obligation under paragraph 1.12.2 (c)2 shall not be limited in any way by any limitation on the amount or type of damages, compensation or benefits payable by or for CONTRACTOR or any such Subcontractor or other person or organization under workers' or workmen's compensation acts, disability benefit acts or other employee benefit acts.

**4.16 Sanitation**

4.16.1 The Contractor shall introduce and enforce among his employees, such regulations in regard to cleanliness and the disposal of garbage and wastes as shall comply with the Local ordinances. The Contractor shall take such means as the Owner may direct to effectually prevent the creation of a nuisance at the work site or any part of the property of the Owner. Under no circumstances shall the Contractor create or maintain a nuisance. The Contractor shall construct toilets and maintain them in a sanitary condition, properly secluded from public observation at such points as shall be approved.

4.16.2 All waste, rubbish and debris – whether personal or from construction related processes – shall be removed from the job site and adjacent properties by hauling away and shall not be buried or discarded.

4.17 Road Closing Requirements

Work within the road right-of-way that necessitates a full closure of the road or any lane restrictions requires that the contractor notify **48 hours prior to the commencement of work** all that apply from the following list:



ROAD CLOSING – NOTIFICATION NUMBERS

Fax, call, or mail notification of road/bridge closing to the appropriate people

Please note date of successful notification

**POLICE, FIRE, EMS**

Elkhart County PSCC (911 Center) 533-4151

**SCHOOLS**

Baugo .....	293-8583	fax:
Concord .....	875-6577	fax: 875-1617
.....		fax: 875-8762
Elkhart .....	262-5695	fax: 262-5750
Fairfield .....	831-2188	fax:
Goshen .....	533-8631	fax:
Middlebury .....	825-9410	fax:
Northwood .....	574-773-3131	fax:

**POST OFFICES**

Bristol .....	848-4713	fax: 533-9998
Elkhart .....	293-5502	fax: 293-5501
Goshen .....	533-3915	fax: 533-8077
Middlebury .....	825-2505	fax:
Wakarusa .....	862-2010	fax:

**NEWS MEDIA**

Elkhart Truth .....	294-1661	fax: 294-3895
Goshen News .....	533-2151	fax: 534-8830
Channel 16 .....	574-631-1616	fax: 293-3297
.....		fax: 631-1639
Channel 22 .....	574-293-3148	fax: 289-0622
Channel 28 .....	574-679-4545	fax: 522-7609

**OTHERS:**

Elkhart County Hwy .....	533-0538
Elkhart County Eng .....	534-9394

Elkhart County requires a written notification of the agencies notified, including time and date of successful notification. This notification must be given to Elkhart County Highway 24 hours prior to road closings or lane restrictions. This may be faxed to Elkhart County Highway.

The Contractor shall notify all applicable offices, agencies, media and schools, including Elkhart County Highway 24 hours prior to the removal of any lane restrictions or closures.

The Contractor shall coordinate the specific timing of the activation of any new signalization system, reopening, etc. When practical, the Contractor shall provide access through the site for emergency vehicle traffic.

ARTICLE 5 - OTHER WORK

5.1 Related Work at Site

OWNER may perform other work related to the Project at the site by OWNER's own forces, have work performed by utility owners, or let other direct contracts.

5.1.1 CONTRACTOR shall afford each utility owner and other contractor who is a party to such a direct contract (or OWNER, if OWNER is performing the additional work with OWNER's employees) proper and safe access to the site and a reasonable opportunity for the introduction and storage of materials and equipment and the execution of such work, and shall properly connect and coordinate the Work with theirs, CONTRACTOR shall do all cutting, fitting and patching of the Work that may be required to make its several parts come together properly and integrate with such other work.

ARTICLE 6 - OWNER'S RESPONSIBILITIES

6.1 Communication

OWNER shall issue all communications to CONTRACTOR through ENGINEER.

6.2 Appointment of Engineer

In case of termination of the employment of ENGINEER, OWNER shall appoint an engineer whom CONTRACTOR makes no reasonable objection to, whose status under the Contract Documents shall be that of the former ENGINEER. Any dispute in connection with such appointment shall be subject to arbitration.

6.3 Payment

OWNER shall furnish the data required of OWNER under the Contract Documents promptly and shall make payments to CONTRACTOR promptly after they are due.

6.4 Change Orders

OWNER is obligated to execute Change Orders as indicated in paragraph 8.4.

6.5 Inspection

OWNER's responsibility in respect of certain inspections, tests and approvals is set forth in paragraph 11.3.

### 6.6 Service Termination

In connection with OWNER's right to stop Work or suspend Work, see paragraphs 11.5 and 13.1. Paragraph 13.2 deals with OWNER's right to terminate services of CONTRACTOR under certain circumstances.

## ARTICLE 7 - ENGINEER'S STATUS DURING CONSTRUCTION

### 7.1 Owner's Representative

ENGINEER will be OWNER's representative during the construction period. The duties and responsibilities and the limitations of authority of ENGINEER as OWNER's representative during construction are set forth in the Contract Documents and shall not be extended without written consent of OWNER and ENGINEER.

### 7.2 Visits to Site

ENGINEER will make visits to the site at intervals appropriate to the various stages of construction to observe the progress and quality of the executed Work and to determine, in general, if the Work is proceeding in accordance with the Contract Documents. ENGINEER will not be required to make exhaustive or continuous on-site inspections to check the quality or quantity of the Work. ENGINEER's efforts will be directed toward providing for OWNER a greater degree of confidence that the completed Work will conform to the Contract Documents. On the basis of such visits and on-site observations as an experienced and qualified design professional, ENGINEER will keep OWNER informed of the progress of the Work and will endeavor to guard OWNER against defects and deficiencies in the Work.

### 7.3 Project Representation

If OWNER and ENGINEER agree, ENGINEER will furnish a Resident Project Representative to assist ENGINEER in observing the performance of the Work.

### 7.4 Clarifications and Interpretations

ENGINEER will issue with reasonable promptness such written clarifications or interpretations of the requirements of the Contract Documents (in the form of Drawings or otherwise) as ENGINEER may determine necessary, which shall be consistent with or reasonably inferable from the overall intent of the Contract Documents.

### 7.5 Authorized Variations in Work

ENGINEER may authorize minor variations in the Work from the requirements of the Contract Documents which do not involve an adjustment in the Contract Price or the Contract Time and are consistent with the overall intent of the Contract Documents.

These may be accomplished by a Field Order and will be binding on OWNER, and also on CONTRACTOR who shall perform the Work involved promptly.

#### 7.6 Rejecting Defective Work

ENGINEER will have authority to disapprove or reject Work which ENGINEER believes to be defective, and will also have authority to require special inspection or testing of the Work at CONTRACTOR'S expense.

#### 7.7 Decisions on Disputes

7.7.1 ENGINEER will be the initial interpreter of the requirements of the Contract Documents and judge of the acceptability of the Work thereunder. Claims, disputes and other matters relating to the acceptability of the Work or the interpretation of the requirements of the Contract Documents pertaining to the performance and furnishing of the Work and claims under Articles 9 and 10 in respect to changes in the Contract Price or Contract Time will be referred initially to ENGINEER in writing with a request for a formal decision in accordance with this paragraph, which ENGINEER will render in writing within a reasonable time. Written notice of each such claim, dispute and other matter will be delivered by the claimant to ENGINEER and the other party to the Agreement promptly (but in no event later than thirty (30) days) after the occurrence of the event giving rise thereto, and written supporting data will be submitted to ENGINEER and the other party within sixty (60) days after such occurrence unless ENGINEER allows an additional period of time to ascertain more accurate data in support of the claim.

7.7.2 When functioning as interpreter and judge under paragraphs 7.7.1 ENGINEER will not show partiality to OWNER or CONTRACTOR and will not be liable in connection with any interpretation or decision rendered in good faith in such capacity.

#### 7.8 Limitations on Engineer's Responsibilities

Neither ENGINEER's authority to act under this Article 7 or elsewhere in the Contract Documents nor any decision made by ENGINEER in good faith either to exercise or not exercise such authority shall give rise to any duty or responsibility of ENGINEER to CONTRACTOR, any Subcontractor, any Supplier, or any other person or organization performing any of the Work, or to any surety for any of them.

7.8.1 ENGINEER will not be responsible for CONTRACTOR's means, methods, techniques, sequences or procedures of construction, or the safety precautions and programs incident thereto, and ENGINEER will not be responsible for CONTRACTOR's failure to perform or furnish the Work in accordance with the Contract Documents.

7.8.2 ENGINEER will not be responsible for the acts or omissions of

CONTRACTOR or of any Subcontractor, any Supplier, or of any other person or organization performing or furnishing any of the Work.

## ARTICLE 8 - CHANGES IN THE WORK

### 8.1 Work Modifications

Without invalidating the Agreement and without notice to any surety, OWNER may, at any time or from time to time, order additions, deletions or revisions in the Work; these will be authorized by a Written Amendment, a Change Order, or a Work Directive Change. Upon receipt of any such document, CONTRACTOR shall promptly proceed with the Work involved which will be performed under the applicable conditions of the Contract Documents (except as otherwise specifically provided).

### 8.2 Disagreement

If OWNER and CONTRACTOR are unable to agree as to the extent, if any, of an increase or decrease in the Contract Price or an extension or shortening of the Contract Time that should be allowed as a result of a Work Directive Change, a claim may be made therefore as provided in Article 9 or Article 10.

### 8.3 Contract Price and Time

CONTRACTOR shall not be entitled to an increase in the Contract Price or an extension of the Contract Time with respect to any Work performed that is not required by the Contract Documents.

8.4 Change orders

OWNER and CONTRACTOR shall execute appropriate Change Orders covering:

8.4.1 Changes in the Work which is ordered by OWNER.

8.4.2 Changes in the Contract Price or Contract Time which are agreed to by the parties.

8.4.3 Changes in the Contract Price or Contract Time which embody the substance of any written decision rendered by ENGINEER.

8.5 Notification of Change

If notice of any change affecting the general scope of the Work or the provisions of the Contract Documents is required by the provisions of any Bond to be given to a surety, the giving of any such notice will be CONTRACTOR's responsibility, and the amount of each applicable Bond will be adjusted accordingly.

ARTICLE 9 - CHANGE OF CONTRACT PRICE

The Contract Price constitutes the total compensation (subject to authorized adjustments) payable to CONTRACTOR for performing the Work. All duties, responsibilities and obligations assigned to or undertaken by CONTRACTOR shall be at his expense without change in the Contract Price.

9.1 Change Order

The Contract Price may only be changed by a Change Order or by a Written Amendment.

9.2 Determination of Contract Price

The value of any Work covered by a Change Order (extra work order) for an increase or decrease in the Contract Price shall be determined in one of the following ways:

9.2.1 Where the Work involved is covered by unit prices contained in the Contract Documents, by application of unit prices to the quantities of the items involved.

9.2.2 On the basis of the actual Cost of the Work, plus the allowable Contractor's mark-up as per INDOT Specification 109.05 added thereon for overhead and profit.

---

### 9.3 Cost of the Work

The term Cost of the Work means the sum of all costs necessarily incurred and paid by CONTRACTOR in the proper performance of the Work. The term Cost of the Work shall **not** include any of the following:

9.3.1 Payroll costs and other compensation of CONTRACTOR's officers, executives, principals (of partnership and sole proprietorships), general managers, attorneys, auditors, accountants, purchasing and contracting agents, CONTRACTOR whether at the site or in CONTRACTOR's principal or a branch office for general administration of the Work.

9.3.2 Expenses of CONTRACTOR's principal and branch offices other than CONTRACTOR's office at the site.

9.3.3 Any part of CONTRACTOR's capital expenses, including interest on CONTRACTOR's capital employed for the Work and charges against CONTRACTOR for delinquent payments.

9.3.4 Cost of premiums for all Bonds and for all insurance whether or not CONTRACTOR is required by the Contract Documents to purchase and maintain the same.

9.3.5 Costs due to the negligence of CONTRACTOR, any Subcontractor, or anyone directly or indirectly employed by any of them or for whose acts any of them may be liable, including but not limited to, the correction of defective Work, disposal of materials or equipment wrongly supplied and making good any damage to property.

## ARTICLE 10 - CHANGE OF CONTRACT TIME

The Contract Time may only be changed by a Change Order or a Written Amendment. Any claim for an extension or shortening of the Contract Time shall be based on written notice delivered by the party making the claim to the other party and to ENGINEER promptly (but in no event later than fifteen (15) days) after the occurrence of the event giving rise to the claim and stating the general nature of the claim. Notice of the extent of the claim with supporting data shall be delivered within thirty (30) days after such occurrence (unless ENGINEER allows an additional period of time to ascertain more accurate data in support of the claim) and shall be accompanied by the claimant's written statement that the adjustment claimed is the entire adjustment to which the claimant has reason to believe it is entitled as a result of the occurrence of said event. All claims for adjustment in the Contract Time shall be determined by ENGINEER.

No extension of Contract Time shall be allowed for weather, changes in quantities placed, or ENGINEER review times set forth in this contract.

ARTICLE 11 - WARRANTY AND GUARANTEE; TESTS AND INSPECTIONS;  
CORRECTION, REMOVAL OR ACCEPTANCE OF DEFECTIVE WORK

11.1 Warranty and Guarantee

CONTRACTOR warrants and guarantees to OWNER and ENGINEER that all Work will be in accordance with the Contract Documents and will not be defective. Prompt notice of all defects shall be given to CONTRACTOR. All defective Work, whether or not in place, may be rejected, corrected or accepted as provided in this Article 11.

11.2 Access to Work

ENGINEER and ENGINEER's representatives, other representatives of OWNER, testing agencies and governmental agencies with jurisdictional interests will have access to the Work at reasonable times for their observation, inspecting and testing. CONTRACTOR shall provide proper and safe conditions for such access.

11.3 Tests and Inspections

CONTRACTOR shall give ENGINEER timely notice of readiness of the Work for all required inspections, tests or approvals.

11.3.1 If Laws or Regulations of any public body having jurisdiction require any Work (or part thereof) to specifically be inspected, tested or approved, CONTRACTOR shall assume full responsibility therefore, pay all costs in connection therewith and furnish ENGINEER the required certificates of inspection, testing or approval.

11.3.2 The Contractor shall assume full responsibility for paying all costs in connection with testing or certification of materials required under INDOT Standard Specifications. In the case of failed or rejected materials or product used in construction of the project either by CONTRACTOR or SUBCONTRACTORS, independent third-party testing may be used at CONTRACTOR'S expense.

11.3.3 If any Work (including the work of others) that is to be inspected, tested or approved is covered without written concurrence of ENGINEER, it must, if requested by ENGINEER, be uncovered for observation. Such uncovering shall be at CONTRACTOR's expense unless CONTRACTOR has given ENGINEER timely notice of CONTRACTOR's intention to cover the same and ENGINEER has not acted with reasonable promptness in response to such notice.

11.3.4 Neither observations by ENGINEER nor inspections, tests or approvals by others shall relieve CONTRACTOR from CONTRACTOR's obligations to perform the Work in accordance with the Contract Documents.



**11.4 Uncovering Work**

11.4.1 If any Work is covered contrary to the written request of ENGINEER, it must, if requested by ENGINEER, be uncovered for ENGINEER's observation and replaced at CONTRACTOR's expense.

11.4.2 If ENGINEER considers it necessary or advisable that covered Work be observed by ENGINEER or inspected or tested by others, CONTRACTOR, at ENGINEER's request, shall uncover, expose or otherwise make available for observation, inspection or testing as ENGINEER may require, that portion of the Work in question, furnishing all necessary labor, material and equipment.

**11.5 Owner May Stop the Work**

If the Work is defective, or CONTRACTOR fails to supply sufficient skilled workers or suitable materials or equipment, or fails to furnish or perform the Work in such a way that the completed Work will conform to the Contract Documents, OWNER may order CONTRACTOR to stop the Work, or any portion thereof, until the cause for such order has been eliminated.

**11.6 Correction or Removal of Defective Work**

If required by ENGINEER, CONTRACTOR shall promptly, as directed, either correct all defective Work, whether or not fabricated, installed or completed, or, if the Work has been rejected by ENGINEER, remove it from the site and replace it with non-defective Work. CONTRACTOR shall bear all direct, indirect and consequential costs of such correction or removal (including but not limited to fees and charges of engineers, attorneys and other professionals) made necessary thereby.

**11.7 Three Years Correction Period**

If, within three (3) years after the date of Final Acceptance, any Work is found to be defective, CONTRACTOR shall promptly, without cost to OWNER and in accordance with OWNER's written instructions, either correct such defective Work, or, if it has been rejected by OWNER and/or Engineer remove it from the site and replace it with non-defective work. If CONTRACTOR does not promptly comply with the terms of such instructions, or in an emergency where delay would cause serious risk of loss or damage, OWNER may have the defective Work corrected or the rejected Work removed and replaced, and all direct, indirect and consequential costs of such removal and replacement (including but not limited to fees and charges of engineers, attorneys and other professionals) will be paid by CONTRACTOR.

**11.8 Maintenance Bond**

Each Contractor shall furnish prior to Final Acceptance a Maintenance Bond (form attached) in an amount at least equal to ten percent (10%) of the Contract Price,

guaranteeing for a period of three (3) years after the date of acceptance by the Owner, that all workmanship and materials entered into the Contract are in accordance with the Plans and Specifications. Each Contractor shall remove any defects due to faulty workmanship and/or materials and shall pay for any damage to other work resulting there from which shall appear within the guarantee period. Should such quality assurance tests, as are called for in the contract Plans and Specifications (e.g., roll test, density, concrete strength, etc.), not be performed or if the work is not performed within reasonable conformity to the Plans and Specifications, the maintenance bond period may be extended to six (6) years.

#### 11.9 Acceptance of Defective Work:

If instead of requiring correction or removal and replacement of defective Work, OWNER prefers to accept it, OWNER may do so. CONTRACTOR shall bear all direct, indirect and consequential costs attributable to OWNER's evaluation of and determination to accept such defective Work. If any such acceptance occurs prior to ENGINEER's recommendation of final payment, a Change Order will be issued incorporating the necessary revisions in the Contract Documents with respect to the Work; and OWNER shall be entitled to an appropriate decrease in the Contract Price.

#### 11.10 OWNER May Correct Defective Work:

If CONTRACTOR fails within a reasonable time after written notice of ENGINEER to proceed to correct and to correct defective Work or to remove and replace rejected Work as required by ENGINEER in accordance with paragraph 11.6, or if CONTRACTOR fails to perform the Work in accordance with the Contract Documents, or if CONTRACTOR fails to comply with any other provision of the Contract Documents, OWNER may, after seven (7) days' written notice to CONTRACTOR, correct and remedy any such deficiency. All direct, indirect and consequential costs of OWNER in exercising such rights and remedies will be charged against CONTRACTOR in an amount approved as to reasonableness by ENGINEER, and a Change Order will be issued incorporating the necessary revisions in the Contract Documents with respect to the Work; and OWNER shall be entitled to an appropriate decrease in the Contract Price.

### ARTICLE 12 - PAYMENTS TO CONTRACTOR AND COMPLETION

#### 12.1 Schedule of Values

The schedule of values (itemized proposal) established at contract unit prices will serve as the basis for progress payments and will be incorporated into a form of Application for Payment acceptable to ENGINEER. Progress payments on account of Unit Price Work will be based on the number of units completed.

#### 12.2 Application for Progress Payment

At least fifteen (15) days before each regularly scheduled County Commissioners

Meeting, CONTRACTOR shall submit to ENGINEER for review an Application for Payment filled out and signed by CONTRACTOR covering the Work completed as of the date of the Application and accompanied by such supporting documentation as is required by the Contract Documents.

### 12.3 Contractor's Warranty of Title

CONTRACTOR warrants and guarantees that title to all Work, materials and equipment covered by any Application for Payment, whether incorporated in the Project or not, will pass to OWNER no later than the time of payment free and clear of all Liens.

### 12.4 Review of Applications for Progress Payment

12.4.1 ENGINEER will, within ten (10) days after receipt of each Application for Payment, either indicate in writing a recommendation of payment and present the Application to OWNER, or return the Application to CONTRACTOR indicating in writing ENGINEER's reasons for refusing to recommend payment. In the latter case, CONTRACTOR may make the necessary corrections and resubmit the Application. Ten (10) days after presentation of the Application for Payment with ENGINEER's recommendation, the amount recommended will become due and when due will be paid by OWNER to CONTRACTOR. All progress payments will be subject to a ten Percent (10%) retainage that will not be released until Maintenance Bond is received.

12.4.2 ENGINEER's recommendation of any payment requested in an Application for Payment will constitute a representation by ENGINEER to OWNER, based on ENGINEER's on-site observations of the Work in progress as an experienced and qualified design professional and on ENGINEER's review of the Application for Payment and the accompanying data and schedules that the Work has progressed to the point indicated; that, to the best of ENGINEER's knowledge, information and belief, the quality of the Work is in accordance with the Contract Documents and that CONTRACTOR is entitled to payment of the amount recommended. However, by recommending any such payment ENGINEER will not thereby be deemed to have represented that exhaustive or continuous on-site inspections have been made to check the quality or the quantity of the Work beyond the responsibilities specifically assigned to ENGINEER in the Contract Documents or that there may not be other matters or issues between the parties that might entitle CONTRACTOR to be paid additionally by OWNER or OWNER to withhold payment to CONTRACTOR.

12.4.3 ENGINEER's recommendation of final payment will constitute an additional representation by ENGINEER to OWNER that the conditions precedent to CONTRACTOR's being entitled to final payment as set forth in paragraph 12.9 have been fulfilled.

12.4.4 ENGINEER may refuse to recommend the whole or any part of any payment if, in ENGINEER's opinion, it would be incorrect to make such

representations to OWNER. ENGINEER may also refuse to recommend any such payment, or, because of subsequently discovered evidence or the results of subsequent inspections or tests, nullify any such payment previously recommended, to such extent as may be necessary in ENGINEER's opinion to protect OWNER from loss because:

- a) The Work is defective, or completed Work has been damaged requiring correction or replacement.
- b) The Contract Price has been reduced by Written Amendment or Change Order.
- c) OWNER has been required to correct defective Work or complete Work in accordance with paragraph 11.10, or
- d) Of ENGINEER's actual knowledge of the occurrence of any of the events enumerated in paragraphs 13.2.1 through 13.2.9 inclusive.

OWNER may refuse to make payment of the full amount recommended by ENGINEER because claims have been made against OWNER on account of CONTRACTOR's performance or furnishing of the Work or Liens have been filed in connection with the Work or there are other items entitling OWNER to a set-off against the amount recommended, but OWNER must give CONTRACTOR immediate written notice (with a copy to ENGINEER) stating the reasons for such action.

## 12.5 Substantial Completion

When CONTRACTOR considers the entire Work ready for its intended use (that is, use by the public) and all work items are complete, CONTRACTOR shall notify OWNER and ENGINEER in writing that the entire Work is substantially complete and request that ENGINEER issue a certificate of Substantial Completion. Within seven (7) calendar days for a contract price under \$1,000,000.00 and fourteen (14) calendar days otherwise, OWNER, CONTRACTOR and ENGINEER shall make an inspection of the Work to determine the status of completion. If ENGINEER does not consider the Work substantially complete, ENGINEER will notify CONTRACTOR in writing giving the reasons therefore. If ENGINEER considers the Work substantially complete, ENGINEER will prepare and deliver to OWNER a tentative certificate of Substantial Completion which shall fix the date of Substantial Completion. There shall be attached to the certificate a tentative list of items to be corrected before final payment.

The ENGINEER may recommend to the OWNER that a Waiver of Time be provided to the CONTRACTOR for the seven (7) or fourteen (14) calendar days listed herein if the CONTRACTOR has demobilized from the site, and there are no remaining defective or incomplete Work items. A Waiver of Time is a document that waives the Liquidated Damages for the seven (7) or fourteen (14) day time-frame. A Waiver of Time may be

given for part or the entirety of the seven (7) or fourteen (14) day period listed herein. The amount of time provided in the Waiver of Time is at the discretion of the OWNER.

## 12.6 Partial Utilization

Use by OWNER of any finished part of the Work, which has specifically been identified in the Contract Documents, or which OWNER, ENGINEER and CONTRACTOR agree constitutes a separately functioning and useable part of the Work that can be used by OWNER without significant interference with CONTRACTOR's performance of the remainder of the Work, may be accomplished prior to Substantial Completion of all the Work subject to the following:

12.6.1 OWNER at any time may request CONTRACTOR in writing to permit OWNER to use any such part of the Work which OWNER believes to be ready for its intended use and substantially complete. If CONTRACTOR agrees, CONTRACTOR will certify to OWNER and ENGINEER that said part of the Work is substantially complete and request ENGINEER to issue a certificate of Substantial Completion for that part of the Work. CONTRACTOR at any time may notify OWNER and ENGINEER in writing that CONTRACTOR considers any such part of the Work ready for its intended use and substantially complete and request ENGINEER to issue a certificate of Substantial Completion for that part of the Work. Within a reasonable time after either such request, OWNER, CONTRACTOR and ENGINEER shall make an inspection of that part of the Work to determine its status of completion. If ENGINEER does not consider that part of the Work to be substantially complete, ENGINEER will notify OWNER and CONTRACTOR in writing giving the reasons therefore. If ENGINEER considers that part of the Work to be substantially complete, the provisions of paragraph 12.5 will apply with respect to certification of Substantial Completion of that part of the Work and the division of responsibility in respect thereof and access thereto.

12.6.2 OWNER may at any time request CONTRACTOR in writing to permit OWNER to take over operation of any such part of the Work although it is not substantially complete. A copy of such request will be sent to ENGINEER and within a reasonable time thereafter OWNER, CONTRACTOR and ENGINEER shall make an inspection of that part of the Work to determine its status of completion and will prepare a list of the items remaining to be completed or corrected thereon before final payment. If CONTRACTOR does not object in writing to OWNER and ENGINEER that such part of the Work is not ready for separate operation by OWNER, ENGINEER will finalize the list of items to be completed or corrected and will deliver such list to OWNER and CONTRACTOR together with a written recommendation as to the division of responsibilities pending final payment between OWNER and CONTRACTOR with respect to security, operation, safety, maintenance, utilities, insurance, warranties and guarantees for that part of the Work which will become binding upon OWNER and CONTRACTOR at the time when OWNER takes over such operation (unless they shall have otherwise agreed in writing and so informed ENGINEER). During such operation and prior to Substantial

Completion of such part of the Work, OWNER shall allow CONTRACTOR reasonable access to complete or correct items on said list and to complete other related Work.

#### 12.7 Final Inspection

Upon written notice from CONTRACTOR that the entire Work or an agreed portion thereof is complete, ENGINEER will make a final inspection with OWNER and CONTRACTOR and will notify CONTRACTOR in writing of all particulars in which this inspection reveals that the Work is incomplete or defective. CONTRACTOR shall immediately take such measures as are necessary to remedy such deficiencies.

#### 12.8 Final Application for Payment

After CONTRACTOR has completed all such corrections to the satisfaction of ENGINEER and delivered all maintenance and operating instructions, schedules, guarantees, Bonds, certificates of inspection, marked-up record documents and other documents--all as required by the Contract Documents, and after ENGINEER has indicated that the Work is acceptable, CONTRACTOR may make application for final payment following the procedure for progress payments.

#### 12.9 Final Payment and Acceptance

12.9.1 If, on the basis of ENGINEER's observation of the Work during construction and final inspection, and ENGINEER's review of the final Application for Payment and accompanying documentation--all as required by the Contract Documents, ENGINEER is satisfied that the Work has been completed and CONTRACTOR's other obligations under the Contract Documents have been fulfilled, ENGINEER will, within ten (10) days after receipt of final Application for Payment, indicate in writing ENGINEER's recommendation of payment and present the Application to OWNER for payment. Thereupon ENGINEER will give written notice to OWNER and CONTRACTOR that the Work is acceptable subject to the provisions of paragraph 12.15. Otherwise, ENGINEER will return the Application to CONTRACTOR, indicating in writing the reasons for refusing to recommend final payment, in which case CONTRACTOR shall make the necessary corrections and resubmit the Application. Thirty (30) days after presentation to OWNER of the Application and accompanying documentation, in appropriate form and substance, and with ENGINEER's recommendation and notice of acceptability, the amount recommended by ENGINEER will become due and will be paid by OWNER to CONTRACTOR.

12.9.2 If, through no fault of CONTRACTOR, final completion of the Work is significantly delayed and if ENGINEER so confirms, OWNER shall, upon receipt of CONTRACTOR's final Application for Payment and recommendation of ENGINEER, and without terminating the Agreement, make payment of the balance due for that portion of the Work fully completed and accepted.

**12.10 Contractor's Continuing Obligation**

CONTRACTOR's obligation to perform and complete the Work in accordance with the Contract Documents shall be absolute. Neither recommendation of any progress or final payment by ENGINEER, nor the issuance of a certificate of Substantial Completion, nor any payment by OWNER to CONTRACTOR under the Contract Documents, nor any use or occupancy of the Work or any part thereof by OWNER, nor any act of acceptance by OWNER nor any failure to do so, nor any review and approval of a Shop Drawing or sample submission, nor the issuance of a notice of acceptability by ENGINEER, nor any correction of defective Work by OWNER will constitute an acceptance of Work not in accordance with the Contract Documents or a release of CONTRACTOR's obligation to perform the Work in accordance with the Contract Documents (except as provided in paragraph 12.11).

**12.11 Waiver of Claims**

The making and acceptance of final payment will constitute:

12.11.1 A waiver of all claims by OWNER against CONTRACTOR, except claims arising from unsettled Liens, from defective Work appearing after final inspection pursuant to paragraph 12.10 or from failure to comply with the Contract Documents or the terms of any special guarantees specified therein; however, it will not constitute a waiver by OWNER of any rights in respect of CONTRACTOR's continuing obligations under the Contract Documents; and

12.11.2 A waiver of all claims by CONTRACTOR against OWNER other than those previously made in writing and still unsettled.

**ARTICLE 13 - SUSPENSION OF WORK AND TERMINATION**

**13.1 OWNER May Suspend Work**

OWNER may, at any time and without cause, suspend the Work or any portion thereof for a period of not more than one hundred eighty (180) days by notice in writing to CONTRACTOR and ENGINEER which will fix the date on which Work will be resumed. CONTRACTOR shall resume the Work on the date so fixed. CONTRACTOR shall be allowed an increase in the extension of the Contract Time directly attributable to any suspension.

**13.2 Conditions of Termination by Owner**

Upon the occurrence of any one or more of the following events:

13.2.1 If CONTRACTOR commences a voluntary case under any chapter of the

Bankruptcy Code (Title 11, United States Code), as now or hereafter in effect, or if CONTRACTOR takes any equivalent or similar action by filing a petition or otherwise under any other federal or state law in effect at such time relating to the bankruptcy or insolvency;

13.2.2 If a petition is filed against CONTRACTOR under any chapter of the Bankruptcy Code as now or hereafter in effect at the time of filing, or if a petition is filed seeking any such equivalent or similar relief against CONTRACTOR under any other federal or state law in effect at the time relating to bankruptcy or insolvency;

13.2.3 If CONTRACTOR makes a general assignment for the benefit of creditors;

13.2.4 If a trustee, receiver, custodian or agent of CONTRACTOR is appointed under applicable law or under contract, whose appointment or authority to take charge of property of CONTRACTOR is for the purpose of enforcing Lien against such property or for the purpose of general administration of such property for the benefit of CONTRACTOR's creditors;

13.2.5 If CONTRACTOR admits in writing an inability to pay its debts generally as they become due;

13.2.6 If CONTRACTOR persistently fails to perform the Work in accordance with the Contract Documents (including, but not limited to, failure to supply sufficient skilled workers or suitable materials or equipment or failure to adhere to the progress schedule established under paragraph 1.7 as revised from time to time);

13.2.7 If CONTRACTOR disregards Laws or Regulations of any public body having jurisdiction;

13.2.8 If CONTRACTOR disregards the authority of ENGINEER; or

13.2.9 If CONTRACTOR otherwise violates in any substantial way any provisions of the Contract Documents;

### 13.3 Termination by Owner

13.3.1 OWNER may, after giving CONTRACTOR and the surety, if there be one, seven (7) days' written notice and to the extent permitted by Laws and Regulations, terminate the services of CONTRACTOR, exclude CONTRACTOR from the site and take possession of the Work and of all CONTRACTOR's tools, appliances, construction equipment and machinery at the site and use the same to the full extent they could be used by CONTRACTOR (without liability to CONTRACTOR for trespass or conversion), incorporate in the Work all materials and equipment stored at the site or for which OWNER has paid CONTRACTOR but which are stored elsewhere, and finish the Work as OWNER may deem expedient. In such case CONTRACTOR shall not be entitled to receive any further payment until the Work



is finished. If the unpaid balance of the Contract Price exceeds the direct, indirect and consequential costs of completing the Work (including but not limited to fees and charges of engineers, attorneys and other professionals and court and arbitration costs) such excess will be paid to CONTRACTOR. If such costs exceed such unpaid balance, CONTRACTOR shall pay the difference to OWNER. Such costs incurred by OWNER will be approved as to reasonableness by ENGINEER and incorporated in a Change Order, but when exercising any rights or remedies under this paragraph OWNER shall not be required to obtain the lowest price for the Work performed.

13.3.2 Where CONTRACTOR's services have been so terminated by OWNER, the termination will not affect any rights or remedies of OWNER against CONTRACTOR then existing or which may thereafter accrue. Any retention or payment of monies due CONTRACTOR by OWNER will not release CONTRACTOR from liability.

13.3.3 Upon seven (7) days' written notice to CONTRACTOR and ENGINEER, OWNER may, without cause and without prejudice to any other right or remedy, elect to abandon the Work and terminate the Agreement. In such case, CONTRACTOR shall be paid for all Work executed and any expense sustained plus reasonable termination expenses, which will include, but not be limited to, direct, indirect and consequential costs (including, but not limited to, fees and charges of engineers, architects, attorneys and other professionals and court and arbitration costs).

#### 13.4 Conditions of Termination by Contractor

13.4.1 If, through no act or fault of CONTRACTOR, the Work is suspended for a period of more than one hundred eighty (180) days by OWNER or under an order of court or other public authority, or ENGINEER fails to act on any Application for Payment within thirty (30) days after it is submitted, or

13.4.2 If OWNER fails for thirty (30) days to pay CONTRACTOR any sum finally determined to be due, then CONTRACTOR may, upon seven (7) days' written notice to OWNER and ENGINEER, terminate the Agreement and recover from OWNER payment for all Work executed and any expense sustained plus reasonable termination expenses. In addition and in lieu of terminating the Agreement, if ENGINEER has failed to act on an Application for Payment or OWNER has failed to make any payment as aforesaid, CONTRACTOR may upon seven (7) days' written notice to OWNER and ENGINEER stop the Work until payment of all amounts then due. The provisions of this paragraph shall not relieve CONTRACTOR of the obligations under paragraph 4.14 to carry on the Work in accordance with the progress schedule and without delay during disputes and disagreements with the OWNER.

ARTICLE 14 - MISCELLANEOUS

14.1 Giving Notice

Whenever any provision of the Contract Documents requires the giving of written notice, it will be deemed to have been validly given if delivered in person to the individual or to a member of the firm or to an officer of the corporation for whom it is intended, or if delivered at or sent by registered or certified mail, postage prepaid, to the last business address known to the giver of the notice.

14.2 Computation of Time

When any period of time is referred to in the Contract Documents by days, it will be computed to exclude the first and include the last day of such period. If the last day of any period falls on a Saturday or Sunday or on a day made a legal holiday by the law of the applicable jurisdiction, such day will be omitted from the computation.

14.2.1 A calendar day of twenty-four hours measured from midnight to the next midnight shall constitute a day.

14.3 Bid Submission

Each bidder who submits a proposal for any portion of the work included in the Project Manual must submit with its bid this form fully completed and signed by an authorized officer of the bidder and must provide the data requested by the form. Unless this form is fully completed and signed by the bidder, the proposal made by that bidder will be incomplete and will not be considered by the Board of County Commissioners.

---

**BID FORM**

1. Name of Bidder \_\_\_\_\_

2. Business Address \_\_\_\_\_

3. Number of years engaged in contracting business under present firm's name: \_\_\_\_\_ years.

4. \*Experience in the contracting work generally similar to this project, including list of complexes, locations and approximate contract cost thereof.

\_\_\_\_\_  
\_\_\_\_\_  
\_\_\_\_\_

5. Have you ever defaulted on a contract? \_\_\_\_\_ Yes \_\_\_\_\_ No  
If Yes, when, with whom and why? \_\_\_\_\_

\_\_\_\_\_

6. \*It is a necessary requirement of this Specification that each Contractor show evidence for five (5) jobs guaranteed for one (1) year on workmanship, unconditionally, and where Contractor has agreed to return and repair this work at no expense to the Owner.

_____	_____
_____	_____
_____	_____

7. \*Have you ever filed bankruptcy or been adjudged bankruptcy?  
\_\_\_\_\_ Yes \_\_\_\_\_ No

8. Do you employ any black, Hispanic, female or oriental minority persons? If yes, please state the number of each of such minority persons you presently employ.  
\_\_\_\_\_ Yes \_\_\_\_\_ No

If no, please state reasons.

\_\_\_\_\_  
\_\_\_\_\_

---

9. Have you encouraged minority building subcontractors to submit proposals in connection with your bid? \_\_\_\_\_ Yes \_\_\_\_\_ No. If yes, state the name(s) of the minority subcontractors who have been contacted by you for the purpose of submitting a bid/proposal. If no, please state reasons.

---

---

---

10. Do you intend to use any minority subcontractors in performing the work or providing the materials contained within your bid? \_\_\_\_\_ Yes \_\_\_\_\_ No. If yes, please state the name of the subcontractor. If no, please state reasons.

---

---

---

11 Have you been involved in any complaints or litigation relative to the use of minority subcontractors? \_\_\_\_\_ Yes \_\_\_\_\_ No. If yes, what is the status of the complaints of the litigation?

---

---

---

12 Additional pertinent comments:

---

---

---

BY: \_\_\_\_\_

\_\_\_\_\_  
(Signature of official completing this form)

---

**BID BOND**

KNOW ALL MEN BY THESE PRESENTS, that we the undersigned \_\_\_\_\_

\_\_\_\_\_ as PRINCIPAL, and \_\_\_\_\_

\_\_\_\_\_ as SURETY, are held and firmly bound unto the Elkhart County Board of County Commissioners, hereinafter called the "Owner", in the penal sum of

\_\_\_\_\_ Dollars (\$\_\_\_\_\_ ) lawful

money of the United States, for the payment of which sum well and truly to be made, we bind ourselves, our heirs, executors, administrators, successors, and assigns, jointly and severally, firmly by these presents:

THE CONDITION OF THIS OBLIGATION IS SUCH, that whereas the Principal has submitted the accompanying Bid, dated \_\_\_\_\_

for: \_\_\_\_\_

NOW, THEREFORE, if the Principal shall not withdraw said bid within the period specified herein after the opening of the same, or if no period be specified within or sixty (60) days after the said opening, and shall within the period specified therefore, or, if no period be specified within ten (10) days after the prescribed forms are presented to him for signature, enter into a written contract with the Owner in accordance with the bid as accepted, and give Bond for faithful performance and proper fulfillment of such Contract; or in the event of the withdrawal of said bid within the period specified, or the failure to enter into such Contract and give such Bond within the time specified if the Principal shall

---

pay the Owner the difference between the amount specified in said Bid and the amount for which the Owner may procure the required work or suppliers or both, if the latter amount be in excess of the former, then the above obligation shall be void and of no effect, otherwise to remain in full force and virtue.

IN WITNESS WHEREOF, the above bounden parties have executed this instrument under their several seals this \_\_\_\_\_ day of \_\_\_\_\_, \_\_\_\_\_ the name and corporate seal of each corporate party being hereto affixed and these presents duly signed by its undersigned representative, pursuant to authority of its governing body.

IN PRESENCES OF:

INDIVIDUAL PRINCIPALS:

_____	_____ (SEAL)
_____	_____ (SEAL)
_____	_____ (SEAL)
_____	_____ (SEAL)

ATTEST:

CORPORATE PRINCIPAL:

_____	_____ (SEAL)
_____	_____ (SEAL)

Business Address \_\_\_\_\_

By: \_\_\_\_\_

Title: \_\_\_\_\_

ATTEST:

CORPORATE SURETY:

_____	_____ (SEAL)
_____	_____ (SEAL)

Business Address \_\_\_\_\_

By: \_\_\_\_\_

Title: \_\_\_\_\_

Power-of-Attorney for person signing for Surety Company must be attached to Bond.

---

**CERTIFICATE AS TO CORPORATE PRINCIPAL**

I, \_\_\_\_\_  
certify that I am the \_\_\_\_\_  
Secretary of the Corporation named as Principal in the within Bond; that \_\_\_\_\_  
\_\_\_\_\_ who signed the said Bond on behalf of the Principal  
was then \_\_\_\_\_ of the corporation, that I know  
his signature, and his signature thereto is genuine; and that said Bond was duly signed,  
sealed, and attested to, for and in behalf of said corporation by authority of its governing  
body.

\_\_\_\_\_ (SEAL)



---

**PERFORMANCE AND PAYMENT BOND**

KNOW ALL MEN BY THESE PRESENTS,

That \_\_\_\_\_ as principal and \_\_\_\_\_ as surety, are firmly bound unto Elkhart County, Indiana, acting through its Board of County Commissioners (OWNER) in the penal sum of an amount equal to one hundred percent (100%) the amount of his bid or the contract price, if the proposal is accepted, for the payment of which, well and truly to be made, we bind ourselves, jointly and severally, and our joint and several heirs, executors, administrators, and assigns, firmly by these presents, this \_\_\_\_ day of \_\_\_\_\_, \_\_\_\_.

THE CONDITIONS OF THE ABOVE OBLIGATION ARE SUCH That, Whereas, the principal is herewith submitting a bid and proposal for the erection, construction and completion of 2025-1 CCMG Paving Program in accordance with the plans and specifications approved and adopted by said OWNER, which are made a part of this bond.

NOW, THEREFORE, if the said OWNER awards said principal the contract for work and said principal promptly enter into a contract with said OWNER (“Construction Agreement”) for the said work and well and faithfully does and performs the same in all respects according to the plans and specifications provided by the said OWNER, and according to the time, terms, and conditions specified in the Construction Agreement, and in

accordance with all requirements of law, and promptly pays all debts incurred by him or any subcontractor in the construction of said work, including labor, service, and materials furnished, then this obligation shall be void; otherwise to remain in full force, virtue and effect.

IT IS AGREED that the principal and surety, jointly and severally, bind themselves, their heirs, executors, administrators, successors, and assigns to the OWNER for the performance of the Construction Agreement including compliance with all of the plans and specifications provided by the OWNER, and according to the time, terms, and conditions specified in the Construction Agreement, and in accordance with all requirements of law. Principal and surety further agree to defend, indemnify, and hold harmless OWNER from claims, demands, liens or suits by any person or entity seeking payment for Principal's failure to perform under the Construction Agreement.

IT IS AGREED that the principal and surety, jointly and severally, bind themselves, their heirs, executors, administrators, successors, and assigns to the OWNER to pay for labor, materials and equipment furnished for use in the performance of the Construction Agreement, which is incorporated herein by reference. Principal and surety further agree to defend, indemnify, and hold harmless OWNER from claims, demands, liens or suits by any person or entity seeking payment for labor, materials, or equipment furnished for use in the performance of the Construction Agreement. The payment bond granted to OWNER is also for the benefit of the subcontractors, laborers, material suppliers, and

those performing services.

IT IS AGREED that no modifications, omissions, or additions in or to the terms and conditions of the Construction Agreement, plans, specifications, drawings, or profile; defect in the Construction Agreement; or defect in the proceedings preliminary to the letting and awarding of the Construction Agreement will discharge or any wise affect the obligation of surety on these bonds.

IN WITNESS WHEREOF, we hereunto set our hands and seal this \_\_\_\_\_ day of \_\_\_\_\_, \_\_\_\_\_.

NAME\_\_\_\_\_

NAME\_\_\_\_\_

ADDRESS\_\_\_\_\_

ADDRESS\_\_\_\_\_

BY\_\_\_\_\_  
Signature Title

BY\_\_\_\_\_  
Signature Title

\_\_\_\_\_  
(Printed or Typed)  
Surety

\_\_\_\_\_  
(Printed or Typed)  
Principal

State of Indiana, County of \_\_\_\_\_ ss:

Personally appeared before me, \_\_\_\_\_

as principal and \_\_\_\_\_

as surety and each acknowledged the execution of the above bond this \_\_\_\_\_ day

of \_\_\_\_\_, \_\_\_\_\_.

BY \_\_\_\_\_  
Signature Notary Public

\_\_\_\_\_  
(Printed or Typed)

Witness my hand and notarial seal the said last named date.

My Commission Expires \_\_\_\_\_, \_\_\_\_\_.

\_\_\_\_\_  
(County of Residence)

Accepted and approved this \_\_\_\_\_ day of \_\_\_\_\_, \_\_\_\_\_.

\_\_\_\_\_  
Bradley D. Rogers, President

\_\_\_\_\_  
Suzanne Weirick, Vice President

\_\_\_\_\_  
Bob Barnes, Member

ATTEST: \_\_\_\_\_  
Patricia A. Pickens, Auditor

---

**MAINTENANCE BOND**

KNOW ALL MEN BY THESE PRESENT: That we, \_\_\_\_\_

\_\_\_\_\_, as

Principal, \_\_\_\_\_ and

\_\_\_\_\_

as Surety, are held and firmly bound to the \_\_\_\_\_

\_\_\_\_\_ in

the sum of \_\_\_\_\_

\_\_\_\_\_

\_\_\_\_\_ Dollars (\$ \_\_\_\_\_ )

for the payment of which sum well and truly to be made, we jointly and severally bind ourselves, our heirs, executors, administrators, and successors, firmly by these present.

THE CONDITIONS OF THE ABOVE OBLIGATION are that, whereas the Principal, entered into a contract with the Owner on the \_\_\_\_\_ day of \_\_\_\_\_, \_\_\_\_\_, to construct \_\_\_\_\_ according to the Plans and Specifications, and also warranting the work and materials as provided in the aforesaid Contract and Specifications, for a period of three (3) years from the date of final acceptance of work by the Owner.

Now, if the said Principal shall faithfully perform and fulfill all the requirements of said Warranty and Guaranty, and make all repairs required under said Guaranty and, in the manner provided for, then this Bond to be null and void, otherwise to be in full force and effect.

IN WITNESS WHEREOF, this statement is executed in two (2) counterparts, each one of which shall be deemed an original, this \_\_\_\_\_ day of \_\_\_\_\_, \_\_\_\_\_.

(SEAL)

Principal

ATTEST:

\_\_\_\_\_ BY: \_\_\_\_\_

Title

Title

(SEAL)

ATTEST:

\_\_\_\_\_ BY: \_\_\_\_\_

Title

Title

APPROVED this \_\_\_\_\_ day of \_\_\_\_\_, \_\_\_\_\_.

ELKHART COUNTY, INDIANA  
By and Through Its  
BOARD OF COUNTY COMMISSIONERS

\_\_\_\_\_  
Bradley D. Rogers, President

\_\_\_\_\_  
Suzanne Weirick, Vice President

\_\_\_\_\_  
Bob Barnes, Member

ATTEST: \_\_\_\_\_  
Patricia A. Pickens, Auditor

## **AGREEMENT**

THIS AGREEMENT, made and entered into this \_\_\_\_ day of \_\_\_\_\_, \_\_\_\_, by and between \_\_\_\_\_ (a corporation organized and existing under the laws of the State of Indiana), hereinafter referred to as the “CONTRACTOR,” and “ELKHART COUNTY, INDIANA,” acting through the Board of Commissioners, hereinafter referred to as the “OWNER.”

WITNESSETH, that the Contractor and the Owner, for the considerations stated herein, mutually agree as follows:

### ARTICLE 1 -- STATEMENT OF WORK

The Contractor shall furnish all supervision, technical personnel, labor, materials, machinery, tools, equipment and services, including utility and transportation services, and traffic control, and perform and complete all work required for 2025-1 CCMG Paving Program, in Elkhart County, Indiana, as more particularly described in the Specifications, Special Provisions, General Requirements, Supplementary Conditions, Terms for Bidding, plans and drawings, and other items contained therein prepared by Elkhart County (“ENGINEER”) and referred to herein as the “Construction Documents.” All such Construction Documents have been reviewed and approved by the parties hereto and all are incorporated herein by reference as a part of this Agreement consistent with Article 4 below. All undertakings, duties, obligations, and performance required of Contractor by the Construction Documents and this Agreement are hereinafter referred to as the “Work.”

### ARTICLE 2 -- CONTRACTOR REPRESENTATIONS

The Contractor represents to Owner that it is fully experienced and properly qualified as an expert to render the performance required for the Work, and that it is properly equipped, organized and financed for performance of this Agreement. Contractor further represents and acknowledges that it is an independent contractor, and that Contractor IS NOT, in any manner or form, an agent, employee, or representative of Owner.

## CONTRACTOR INDEMNIFICATION

The Contractor agrees to indemnify and save harmless the Owner and Engineer, their agents and employees, from and against all loss or expense (including court costs and attorneys' fees of defense or enforcement) by reason of liability imposed by law or otherwise upon the Owner or Engineer, for (1) damages because of bodily injury, including death at any time resulting therefrom, sustained by any person or persons, or (2) on account of damage to property or property rights or interests, including loss of use thereof, arising out of or in consequence of the performance of the Work, provided such injury to persons or damage to property is due or claimed to be due to negligence of the Contractor, its subcontractors, employees or agents, or in violation of this Agreement.

## REQUIREMENTS FOR CONTRACTORS ON PUBLIC WORKS PROJECTS

- 1) The provisions of Indiana Code Section 5-16-13 are hereby incorporated by reference including, but not limited to, the following specific provisions:
  - a) Contractor must contribute in work performed by its employees, materials supplied directly by Contractor, and services supplied directly by its employees of at least fifteen percent (15%) of the total contract price.
  - b) Contractor must maintain general liability insurance in the amounts provided in the Construction Documents but in no event less than One Million Dollars (\$1,000,000.00) for each occurrence limit and Two Million Dollars (\$2,000,000.00) for the general aggregate limit.
  - c) Contractor must implement and comply with the requirements of Indiana Code Section 22-5-1.7 concerning the E-Verify system with respect to its employee hiring. Contractor must submit, before work begins on the Agreement, the E-Verify case verification number for each individual who is required to be verified under Indiana Code Section 22-5-1.7. An individual who is required to be verified under Indiana Code Section 22-5-1.7 whose final



case result is final non-confirmation may not be employed on this Work.

- d) Contractor may not pay cash to any individual employed by the Contractor for work done by the individual on this Work.
  - e) Contractor must be in compliance with the Federal Fair Labor Standards Act of 1938, as amended (29 USC 201-209) and Indiana Code Section 22-2-2-1 through Indiana Code Section 22-2-2-8.
  - f) Contractor must be in compliance with Indiana Code Section 22-3-5-1 and Indiana Code Section 22-3-7-34.
  - g) Contractor must be in compliance with Indiana Code Section 22-4-1 through Indiana Code Section 22-4-39.5.
  - h) Contractor must be in compliance with Indiana Code Section 4-13-18-1 through Indiana Code Section 4-13-18-7.
- 2) Drug Testing of Employees. Indiana Code Section 4-13-18 regarding the drug testing of employees of public works contractors applies to the Agreement as the estimated cost hereof is at least One Hundred Fifty Thousand Dollars (\$150,000.00) and has been awarded after June 30, 2015.
- 3) Nondiscrimination. Pursuant to Indiana Code Section 22-9-1-10, Contractor and its subcontractors, if any, shall not discriminate against any employee or applicant for employment to be employed in the performance of the Agreement with respect to hire, tenure, terms, conditions or privileges of employment or any matter directly or indirectly related to employment, because of race, religion, color, sex, disability, national origin, ancestry, or veteran status. Breach of this covenant may be regarded as a material breach of the Agreement.
- 4) Anti-nepotism. Contractor is aware of the provisions of Indiana Code Section 36-1-21 et seq. with respect to anti-nepotism in contractual relationships with governmental entities. Contractor certifies that none of the owners of Contractor is a relative of any elected Council

Member or Commissioner of the County of Elkhart, Indiana.

- 5) Investment Activity. Pursuant to Indiana Code Section 5-22-16.5-13, Contractor certifies that Contractor is not engaged in investment activities in Iran.

ARTICLE 3 -- THE CONTRACT PRICE

The Owner will pay the Contractor for the performance of the Work subject to additions and deductions provided herein, in current funds, and per applicable Indiana law and the required procedures for payments by Owner, the sum of \$\_\_\_\_\_. The Contractor shall start the Work on or after **Monday April 28, 2025**, be substantially complete by **October 3, 2025** and receive final acceptance on or before **Friday October 3rd, 2025**. Any Work remaining to be completed after **October 3, 2025** or Final Acceptance has not been received by **Friday October 3rd, 2025** is subject to the following damages:

For each and every day Work contemplated in this Agreement fails to achieve substantial completion, beyond the substantial completion date herein established (October 3, 2025) or final acceptance has not been received by the final acceptance date herein established (Friday October 3rd, 2025), Contractor shall owe and pay to Owner the sum of \$1,000 per day, as liquidated damages and not as penalty. In establishing said \$1,000 sum per day as and for liquidated damages owed by the Contractor to Owner, the parties hereto stipulate and agree that the actual damages that would be suffered by Owner because of the failure of Contractor to timely complete the Work contemplated are indefinite and uncertain; however, the parties hereto stipulate that the sum herein established is a reasonable estimate by the parties of the probably damages to be suffered by the Owner upon the failure of the Contractor to timely complete the Work contemplated. The liquidated damages herein established shall be deducted daily from the Contract Price herein established, thereby reducing the same for the total amount of liquidated damages as herein stipulated, and hence reducing payments of the Contract Price Owner would otherwise make. If an intermediate date is specified for one or more of the items or phases of the contract, liquidated damages will apply for that particular item or phase as if the intermediate date

specified for said item or phase is conclusion of said portion of project or contract.

#### ARTICLE 4 -- CONTRACT DOCUMENTS

The Contract Documents forming a part of this Agreement by reference shall consist of the following:

- a. This Agreement.
- b. Memos:
- c. Invitation for Bids.
- d. Notice to Bidders.
- e. Signed copy of Bid and Itemized Bid Form.
- f. General Conditions and Supplementary Conditions.
- g. Construction Specifications and Related Documents.
- h. Plans.
- i. Addendums

#### ARTICLE 5 -- PROJECT CONTROL

The Contractor will carry out this project and complete the Work under the direction of the Owner and the Owner's agents, the Engineer, or other consultant designated by the Owner. The Owner's designated representative during the construction period will make visits to the site at intervals appropriate to the various states of construction to observe the progress and quality of the executed Work and to determine, in general, if the Work is proceeding in accordance with the Contract Documents.

This Agreement, to include the Contract Documents enumerated in Article 4 above, constitutes the full agreement and understanding of the parties hereto, and save for change orders and procedures therefore set forth within the Contract Documents, shall not be amended by the parties, other than by instrument executed by each party hereto.

IN WITNESS WHEREOF, the parties hereto have caused this Agreement to be executed in various counterparts effective as of the date and year first above written.

CONTRACTOR:

By \_\_\_\_\_ Signature

\_\_\_\_\_ Printed Name

\_\_\_\_\_ Title

OWNER: **ELKHART COUNTY, INDIANA**, by and through its Board of County Commissioners

\_\_\_\_\_  
Bradley D. Rogers, President

\_\_\_\_\_  
Suzanne M. Weirick, Vice-President

\_\_\_\_\_  
Bob Barnes, Member

ATTEST: \_\_\_\_\_  
Patricia A. Pickens, Auditor

**Division 2:**

# **Bid Documents**

For

## **2025-1 CCMG Paving Program**

---

**OWNERS:**

ELKHART COUNTY, INDIANA, ACTING THROUGH  
IT'S BOARD OF COUNTY COMMISSIONERS  
ELKHART COUNTY HIGHWAY DEPARTMENT  
ENGINEERING SECTION  
610 STEURY AVENUE  
GOSHEN, IN 46528



Elkhart County Highway Department  
610 Steury Avenue, Goshen, Indiana 46528  
Phone: 574-534-9394 • Fax: 574-533-7103

## NOTICE TO BIDDERS

Notice is hereby given that the Board of County Commissioners of Elkhart County, Indiana, will receive bids up to **9:00 AM on Monday April 14th, 2025** for the **2025-1 CCMG Paving Program**. It is the responsibility of the bidder to ensure that its bid is delivered on time to the Office of the Elkhart County Commissioners, County Administration Building, 117 N. Second Street, Goshen, IN 46526.

Plans, Specifications and bidding documents may be obtained from the **Elkhart County Highway Department, website** at [www.elkcohw.org](http://www.elkcohw.org) starting at **9:00 AM on Friday March 14th, 2025**. Plans, Specifications and Bidding Documents may not be obtained prior to this date.

Plans, Specifications and Bidding Documents will be available for inspection at the Elkhart County Highway Department Office, 610 Steury Ave, Goshen, Indiana starting on **Friday March 14th, 2025**. A pre-bid meeting will be held at the Elkhart County Highway Department Office, 610 Steury Ave, Goshen, Indiana at **9:00 AM on Thursday March 27th, 2025**.

Proposals shall be properly and completely executed on proposal forms furnished by the County in accordance with Revised Indiana Form 96 and shall be accompanied by the Contractor's Financial Statement form taken from Form 96 for any proposal of \$5,000 or more.

The Contractor shall submit an itemized proposal of the approximate quantities and components of labor and materials to complete the contract. Said proposal shall be upon the standard bid sheets used by Elkhart County, and said sheet must contain an authorized signature of the Contractor, or the bid of the Contractor may, at the discretion of Elkhart County, be rejected and declared invalid. Each proposal shall be accompanied by a non-collusion affidavit as required by the Statutes of Indiana. Bids shall be enclosed in a sealed envelope, bearing the title of the project and name and address of bidder.

Bids will be accepted only from bidders who are sufficiently and currently pre-qualified by the Indiana Department of Transportation. Proof of pre-qualifications must be submitted with the bid.

A current Contractor's Financial Statement taken from Form 96 and the Indiana Department of Transportation pre-qualification certificate may be placed on file with the Board of County Commissioners of Elkhart County at the Highway Division annually in lieu of executing these documents for each project.

All work may begin on **Monday April 28, 2025** and shall be completed by **Friday October 3rd, 2025**. Delays in completion beyond that date shall result in liquidated damages levied against the Contractor by Elkhart County. The damage charges shall be \$1,000 per day per item beyond the above stated date and any intermediate completion dates noted in the specifications.

A satisfactory bid bond (10% of bid), payable to the Board of County Commissioners of Elkhart County, Indiana executed by the bidder shall be submitted with each bid.

No bids shall be withdrawn after the opening of the bids without the consent of the Board of Commissioners of Elkhart County for a period of thirty (30) days after the scheduled time of closing.

Said work shall be subject to all the provisions of the plans and specifications therefore herein above referred to including the completion date thereof and penalty clause as therein set forth.

The Board of County Commissioners reserves the right to reject any and all Bids or to waive any informalities in the bidding.

Dated this 10th day of March, 2025  
Board of County Commissioners of Elkhart County  
By Patricia A. Pickens, Auditor

Advertise: Wednesday March 12th, 2025 and Wednesday March 19<sup>th</sup>, 2025 - Elkhart Truth and Goshen News

The approximate quantities for this contract are as shown on the itemized bid tabs included on the attached pages. If extra work is necessary due to shifting of any of the items of construction or if additional work is called for in accordance with these specifications, such work shall be paid for on the basis of the following itemized unit prices. In addition to the above, the said unit prices shall also be the basis of payment to the Contractor for actual material placed. The attached sheet (s) must be completely filled out and submitted with the sealed bid or Elkhart County may at its discretion, reject the bid and declare the same invalid. An authorized signature of the Contractor is mandatory upon the bid sheets. All other items necessary to properly complete this project or specifically outlined, shall be included within the line items provided and will be considered as incidental. The award of this contract will be based on the sum of BID TOTAL (BASE AND ALTERNATE BID SUM). Please recognize that the quantities provided are estimated. Elkhart County is not responsible for any wrong formulas or miscalculations in the attached excel Contractor Bid sheet.

This Bid shall be so prepared as to properly indicate:

One (1) total lump sum to furnish labor, materials, services and equipment to perform the work indicated in the bid materials (drawings, specifications and or as specified herein). The Award of this project will be based on the "Total" bid price for BASE BID TOTAL and for ALTERNATE BID TOTAL, being the total sum of the items within that Group on the itemized bid tab. Please indicate this total below.

**NOTE:** Any Item may be withdrawn by Elkhart County at any time prior to the placement of the material.

**BASE BID TOTAL (CC and EC items):** \_\_\_\_\_ dollars

(\$ \_\_\_\_\_ )

**ALTERNATE BID TOTAL (ALT 1 item):** \_\_\_\_\_ dollars

(\$ \_\_\_\_\_ )

**BID TOTAL (BASE AND ALTERNATE BID SUM)** \_\_\_\_\_ dollars

(\$ \_\_\_\_\_ )

**Acknowledge Receipt of Addenda No.(s)** \_\_\_\_\_.

2025-1 CCMG Paving Program

---

Submitted by: \_\_\_\_\_  
Company

\_\_\_\_\_  
Authorized Signature

Date: \_\_\_\_\_ Phone: \_\_\_\_\_



				BID						
Group	Item	Road	Shape Length	Approx. Miles	Road Width	Sq Yards	Unit	Unit Quantities	Price per Unit	Extension
CC	1	County Road 13 from County Road 18 to County Road 16	2,820	0.53	26.00	8,146				
		Prep Cost (Mill)					LS	1		\$0.00
		Asphalt Milling (2 inches)					SYS	8,146		\$0.00
		Tack Coat					SYS	8,146		\$0.00
		Joint Seal					LFT	2,820		\$0.00
		220 lb/yd <sup>2</sup> HMA 12.5 mm, Surface, Type B, 58S-28					TON	897		\$0.00
		Adjust Casting to Grade					EACH	3		\$0.00
		Line, Paint, Solid, Yellow 4"					LFT	5,640		\$0.00
		Line, Paint, Solid, White 4"					LFT	5,640		\$0.00
		#53 Gravel Shoulders					TON	200		\$0.00
TOTAL FOR ITEM									\$0.00	

				BID						
Group	Item	Road	Shape Length	Approx. Miles	Road Width	Sq Yards	Unit	Unit Quantities	Price per Unit	Extension
CC	2	County Road 46 from State Road 19 to County Road 11	15,840	3.00	24.00	42,240				
		Prep Cost (Mill)					LS	1		\$0.00
		Asphalt Milling (2 inches)					SYS	42,240		\$0.00
		Tack Coat					SYS	42,240		\$0.00
		Joint Seal					LFT	15,840		\$0.00
		220 lb/yd <sup>2</sup> HMA 12.5 mm, Surface, Type B, 58S-28					TON	4,647		\$0.00
		Line, Paint, Solid, Yellow 4"					LFT	5,025		\$0.00
		Line, Paint, Dashed, Yellow 4"					LFT	3,960		\$0.00
		Pavement Markings, Thermoplastic, White, Stop Bar, 24"					LFT	12		\$0.00
		#53 Gravel Shoulders					TON	600		\$0.00
TOTAL FOR ITEM									\$0.00	

				BID						
Group	Item	Road	Shape Length	Approx. Miles	Road Width	Sq Yards	Unit	Unit Quantities	Price per Unit	Extension
CC	3	County Road 28 from County Road 13 to County Road 11 - PAVING EXCEPTION FOR BRIDGE #149	5,280	1.00	24.00	14,080				
		Prep Cost (Grind)					LS	1		\$0.00
		Asphalt Grinding Full Depth					SYS	14,080		\$0.00
		Joint Seal					LFT	5,280		\$0.00
		275 lb/yd <sup>2</sup> HMA, 12.5 mm, Surface, Type B, 58S-28					TON	1,936		\$0.00
		#53 Gravel Shoulders					TON	200		\$0.00
		Line, Paint, Solid, Yellow 4"					LFT	5,280		\$0.00
		Line, Paint, Dashed, Yellow 4"					LFT	927		\$0.00
		Pavement Markings, Thermoplastic, White, Stop Bar, 24"					LFT	12		\$0.00
TOTAL FOR ITEM									\$0.00	

				BID						
Group	Item	Road	Shape Length	Approx. Miles	Road Width	Sq Yards	Unit	Unit Quantities	Price per Unit	Extension
CC	4	County Road 7 from County Road 52 to County Road 46	13,200	2.50	24.00	35,200				
		Prep Cost (Mill)					LS	1		\$0.00
		Asphalt Milling (2 inches)					SYS	35,200		\$0.00
		Tack Coat					SYS	35,200		\$0.00
		Joint Seal					LFT	13,200		\$0.00
		220 lb/yd <sup>2</sup> HMA 12.5 mm, Surface, Type B, 58S-28					TON	3,872		\$0.00
		Line, Paint, Solid, Yellow 4"					LFT	4,993		\$0.00
		Line, Paint, Dashed, Yellow 4"					LFT	927		\$0.00
		#53 Gravel Shoulders					TON	500		\$0.00
TOTAL FOR ITEM									\$0.00	

		BID								
Group	Item	Road	Shape Length	Approx. Miles	Road Width	Sq Yards	Unit	Unit Quantities	Price per Unit	Extension
CC	5A	County Road 111 from County Road 20 to Shaffer Ave	2,144	0.41	22.00	5,240				
		Prep Cost (Mill)					LS	1		\$0.00
		Asphalt Milling (2 inches)					SYS	5,240		\$0.00
		Tack Coat					SYS	5,240		\$0.00
		Joint Seal					LFT	2,144		\$0.00
		220 lb/yd <sup>2</sup> HMA 12.5 mm, Surface, Type B, 58S-28					TON	577		\$0.00
		Line, Paint, Solid, Yellow 4"					LFT	4,287		\$0.00
		#53 Gravel Shoulders					TON	200		\$0.00
		TOTAL FOR ITEM								

		BID								
Group	Item	Road	Shape Length	Approx. Miles	Road Width	Sq Yards	Unit	Unit Quantities	Price per Unit	Extension
CC	6	County Road 7 from County Road 38 to County Road 36	5,269	1.00	22.00	12,881				
		Prep Cost (Grind)					LS	1		\$0.00
		Asphalt Grinding Full Depth					SYS	12,881		\$0.00
		Joint Seal					LFT	5,270		\$0.00
		275 lb/yd <sup>2</sup> HMA, 12.5 mm, Surface, Type B, 58S-28					TON	1,772		\$0.00
		#53 Gravel Shoulders					TON	200		\$0.00
		TOTAL FOR ITEM								

		BID								
Group	Item	Road	Shape Length	Approx. Miles	Road Width	Sq Yards	Unit	Unit Quantities	Price per Unit	Extension
CC	7	County Road 24 from State Road 15 to County Road 27	6,547	1.24	22.00	16,004				
		Prep Cost (Grind)					LS	1		\$0.00
		Asphalt Grinding Full Depth					SYS	16,005		\$0.00
		Joint Seal					LFT	6,548		\$0.00
		275 lb/yd <sup>2</sup> HMA, 12.5 mm, Surface, Type B, 58S-28					TON	2,201		\$0.00
		#53 Gravel Shoulders					TON	200		\$0.00
TOTAL FOR ITEM									\$0.00	

		BID								
Group	Item	Road	Shape Length	Approx. Miles	Road Width	Sq Yards	Unit	Unit Quantities	Price per Unit	Extension
CC	8	County Road 11 from County Road 48 to County Road 46	5,280	1.00	22.00	12,907				
		Prep Cost (Grind)					LS	1		\$0.00
		Asphalt Grinding Full Depth					SYS	12,907		\$0.00
		Joint Seal					LFT	5,280		\$0.00
		275 lb/yd <sup>2</sup> HMA, 12.5 mm, Surface, Type B, 58S-28					TON	1,775		\$0.00
		#53 Gravel Shoulders					TON	200		\$0.00
TOTAL FOR ITEM									\$0.00	

		BID								
Group	Item	Road	Shape Length	Approx. Miles	Road Width	Sq Yards	Unit	Unit Quantities	Price per Unit	Extension
CC	9	County Road 46 from State Road 19 to County Road 1	10,560	2.00	24.00	28,160				
		Prep Cost (Grind)					LS	1		\$0.00
		Asphalt Grinding Full Depth					SYS	28,160		\$0.00
		Joint Seal					LFT	10,560		\$0.00
		275 lb/yd <sup>2</sup> HMA, 12.5 mm, Surface, Type B, 58S-28					TON	3,872		\$0.00
		#53 Gravel Shoulders					TON	200		\$0.00
TOTAL FOR ITEM									\$0.00	

		BID									
Group	Item	Road	Shape Length	Approx. Miles	Road Width	Sq Yards	Unit	Unit Quantities	Price per Unit	Extension	
CC	10	County Road 11 from County Road 11N to County Road 11S	2,534	0.48	24.00	6,758					
		Prep Cost (Mill)					LS	1			\$0.00
		Asphalt Milling (2 inches)					SYS	6,759			\$0.00
		Tack Coat					SYS	2,535			\$0.00
		Joint Seal					LFT	2,535			\$0.00
		220 lb/yd <sup>2</sup> HMA 12.5 mm, Surface, Type B, 58S-28					TON	744			\$0.00
		Line, Paint, Solid, Yellow 4"					LFT	1,815			\$0.00
		Line, Paint, Dashed, Yellow 4"					LFT	634			\$0.00
		#53 Gravel Shoulders					TON	200			\$0.00
		TOTAL FOR ITEM									\$0.00

		BID									
Group	Item	Road	Shape Length	Approx. Miles	Road Width	Sq Yards	Unit	Unit Quantities	Price per Unit	Extension	
CC	11	County Road 48 from County Road 11 to County Road 13	5,280	1.00	22.00	12,907					
		Prep Cost (Grind)					LS	1			\$0.00
		Asphalt Grinding Full Depth					SYS	12,907			\$0.00
		Joint Seal					LFT	5,280			\$0.00
		275 lb/yd <sup>2</sup> HMA, 12.5 mm, Surface, Type B, 58S-28					TON	1,775			\$0.00
		#53 Gravel Shoulders					TON	400			\$0.00
		TOTAL FOR ITEM									\$0.00

		BID									
Group	Item	Road	Shape Length	Approx. Miles	Road Width	Sq Yards	Unit	Unit Quantities	Price per Unit	Extension	
CC	12	County Road 146 from County Road 29 to County Road 31	5,280	1.00	22.00	12,907					
		Prep Cost (Grind)					LS	1			\$0.00
		Asphalt Grinding Full Depth					SYS	12,907			\$0.00
		Joint Seal					LFT	5,280			\$0.00
		275 lb/yd <sup>2</sup> HMA, 12.5 mm, Surface, Type B, 58S-28					TON	1,775			\$0.00
		#53 Gravel Shoulders					TON	400			\$0.00
TOTAL FOR ITEM									\$0.00		

		BID									
Group	Item	Road	Shape Length	Approx. Miles	Road Width	Sq Yards	Unit	Unit Quantities	Price per Unit	Extension	
CC	13	County Road 50 from County Road 29 to County Road 31	3,221	0.61	22.00	7,873					
		Prep Cost (Grind)					LS	1			\$0.00
		Asphalt Grinding Full Depth					SYS	7,874			\$0.00
		Joint Seal					LFT	3,221			\$0.00
		275 lb/yd <sup>2</sup> HMA, 12.5 mm, Surface, Type B, 58S-28					TON	1,083			\$0.00
		#53 Gravel Shoulders					TON	400			\$0.00
TOTAL FOR ITEM									\$0.00		

		BID									
Group	Item	Road	Shape Length	Approx. Miles	Road Width	Sq Yards	Unit	Unit Quantities	Price per Unit	Extension	
CC	14A	Forrest Lakes Dr from State Road 120 to End	4,594	0.87	26.00	13,270					
		Prep Cost (Mill)					LS	1			\$0.00
		Asphalt Milling (2 inches)					SYS	13,271			\$0.00
		Tack Coat					SYS	13,271			\$0.00
		Joint Seal					LFT	4,594			\$0.00
		220 lb/yd <sup>2</sup> HMA 12.5 mm, Surface, Type B, 58S-28					TON	1,460			\$0.00
		Topsoil Shoulders					TON	200			\$0.00
TOTAL FOR ITEM									\$0.00		

		BID								
Group	Item	Road	Shape Length	Approx. Miles	Road Width	Sq Yards	Unit	Unit Quantities	Price per Unit	Extension
CC	14B	Poplar Ln from End to End	317	0.06	24.00	2,125				
		Prep Cost (Mill)					LS	1		\$0.00
		Asphalt Milling (2 inches)					SYS	2,126		\$0.00
		Tack Coat					SYS	2,126		\$0.00
		Joint Seal					LFT	317		\$0.00
		220 lb/yd <sup>2</sup> HMA 12.5 mm, Surface, Type B, 58S-28					TON	234		\$0.00
		Topsoil Shoulders					TON	50		\$0.00
		TOTAL FOR ITEM								

		BID								
Group	Item	Road	Shape Length	Approx. Miles	Road Width	Sq Yards	Unit	Unit Quantities	Price per Unit	Extension
CC	14C	Crabapple Ln from Forrest Lakes Dr to End	407	0.08	24.00	1,516				
		Prep Cost (Mill)					LS	1		\$0.00
		Asphalt Milling (2 inches)					SYS	1,516		\$0.00
		Tack Coat					SYS	1,516		\$0.00
		Joint Seal					LFT	407		\$0.00
		220 lb/yd <sup>2</sup> HMA 12.5 mm, Surface, Type B, 58S-28					TON	167		\$0.00
		Topsoil Shoulders					TON	25		\$0.00
		TOTAL FOR ITEM								

		BID								
Group	Item	Road	Shape Length	Approx. Miles	Road Width	Sq Yards	Unit	Unit Quantities	Price per Unit	Extension
CC	14D	Redwood Ln from Forrest Lakes Dr to End	298	0.06	24.00	1,165				
		Prep Cost (Mill)					LS	1		\$0.00
		Asphalt Milling (2 inches)					SYS	1,166		\$0.00
		Tack Coat					SYS	1,166		\$0.00
		Joint Seal					LFT	298		\$0.00
		220 lb/yd <sup>2</sup> HMA 12.5 mm, Surface, Type B, 58S-28					TON	129		\$0.00
		Topsoil Shoulders					TON	25		\$0.00
		TOTAL FOR ITEM								

		BID								
Group	Item	Road	Shape Length	Approx. Miles	Road Width	Sq Yards	Unit	Unit Quantities	Price per Unit	Extension
CC	14E	Juniper Ln from Forrest Lakes Dr to End	317	0.06	24.00	1,626				
		Prep Cost (Mill)					LS	1		\$0.00
		Asphalt Milling (2 inches)					SYS	1,627		\$0.00
		Tack Coat					SYS	1,627		\$0.00
		Joint Seal					LFT	317		\$0.00
		220 lb/yd <sup>2</sup> HMA 12.5 mm, Surface, Type B, 58S-28					TON	179		\$0.00
		Topsoil Shoulders					TON	25		\$0.00
		TOTAL FOR ITEM								

		BID								
Group	Item	Road	Shape Length	Approx. Miles	Road Width	Sq Yards	Unit	Unit Quantities	Price per Unit	Extension
CC	14F	Cypress Ln from Forrest Lakes Dr to End	244	0.05	24.00	995				
		Prep Cost (Mill)					LS	1		\$0.00
		Asphalt Milling (2 inches)					SYS	996		\$0.00
		Tack Coat					SYS	996		\$0.00
		Joint Seal					LFT	244		\$0.00
		220 lb/yd <sup>2</sup> HMA 12.5 mm, Surface, Type B, 58S-28					TON	110		\$0.00
		Topsoil Shoulders					TON	25		\$0.00
		TOTAL FOR ITEM								

		BID								
Group	Item	Road	Shape Length	Approx. Miles	Road Width	Sq Yards	Unit	Unit Quantities	Price per Unit	Extension
CC	14G	Aspen Ln from Forrest Lakes Dr to End	264	0.05	24.00	1,069				
		Prep Cost (Mill)					LS	1		\$0.00
		Asphalt Milling (2 inches)					SYS	1,070		\$0.00
		Tack Coat					SYS	1,070		\$0.00
		Joint Seal					LFT	264		\$0.00
		220 lb/yd <sup>2</sup> HMA 12.5 mm, Surface, Type B, 58S-28					TON	118		\$0.00
		Topsoil Shoulders					TON	25		\$0.00
		TOTAL FOR ITEM								

		BID								
Group	Item	Road	Shape Length	Approx. Miles	Road Width	Sq Yards	Unit	Unit Quantities	Price per Unit	Extension
CC	14H	Butternut Dr from Forrest Lakes Dr to End	558	0.11	24.00	1,922				
		Prep Cost (Mill)					LS	1		\$0.00
		Asphalt Milling (2 inches)					SYS	1,922		\$0.00
		Tack Coat					SYS	1,922		\$0.00
		Joint Seal					LFT	558		\$0.00
		220 lb/yd <sup>2</sup> HMA 12.5 mm, Surface, Type B, 58S-28					TON	212		\$0.00
		Topsoil Shoulders					TON	25		\$0.00
		TOTAL FOR ITEM								

		BID								
Group	Item	Road	Shape Length	Approx. Miles	Road Width	Sq Yards	Unit	Unit Quantities	Price per Unit	Extension
CC	15A	Timber Ridge Dr from County Road 19 to Beech Grove Dr	808	0.15	24.00	2,154				
		Prep Cost (Mill)					LS	1		\$0.00
		Asphalt Milling (2 inches)					SYS	2,155		\$0.00
		Tack Coat					SYS	2,155		\$0.00
		Joint Seal					LFT	808		\$0.00
		220 lb/yd <sup>2</sup> HMA 12.5 mm, Surface, Type B, 58S-28					TON	237		\$0.00
		Topsoil Shoulders					TON	25		\$0.00
		TOTAL FOR ITEM								

		BID								
Group	Item	Road	Shape Length	Approx. Miles	Road Width	Sq Yards	Unit	Unit Quantities	Price per Unit	Extension
CC	15B	Red Oak Ct from Timber Ridge Dr to End	343	0.06	24.00	1,349				
		Prep Cost (Mill)					LS	1		\$0.00
		Asphalt Milling (2 inches)					SYS	1,350		\$0.00
		Tack Coat					SYS	1,350		\$0.00
		Joint Seal					LFT	343		\$0.00
		220 lb/yd <sup>2</sup> HMA 12.5 mm, Surface, Type B, 58S-28					TON	149		\$0.00
		Topsoil Shoulders					TON	25		\$0.00
		TOTAL FOR ITEM								

		BID								
Group	Item	Road	Shape Length	Approx. Miles	Road Width	Sq Yards	Unit	Unit Quantities	Price per Unit	Extension
CC	15C	Sugar Maple Ct from Timber Ridge Dr to End	416	0.08	24.00	1,608				
		Prep Cost (Mill)					LS	1		\$0.00
		Asphalt Milling (2 inches)					SYS	1,608		\$0.00
		Tack Coat					SYS	1,608		\$0.00
		Joint Seal					LFT	416		\$0.00
		220 lb/yd <sup>2</sup> HMA 12.5 mm, Surface, Type B, 58S-28					TON	177		\$0.00
		Topsoil Shoulders					TON	25		\$0.00
		TOTAL FOR ITEM								

										BID			
Group	Item	Road	Shape Length	Approx. Miles	Road Width	Sq Yards	Unit	Unit Quantities	Price per Unit	Extension			
CC	15D	Beech Grove Dr from End to End	920	0.17	24.00	3,216							
		Prep Cost (Mill)					LS	1		\$0.00			
		Asphalt Milling (2 inches)					SYS	3,216		\$0.00			
		Tack Coat					SYS	3,216		\$0.00			
		Joint Seal					LFT	920		\$0.00			
		220 lb/yd <sup>2</sup> HMA 12.5 mm, Surface, Type B, 58S-28					TON	354		\$0.00			
		Topsoil Shoulders					TON	25		\$0.00			
		TOTAL FOR ITEM									\$0.00		

**Total CCMG 2025-1 \$0.00**

										BID			
Group	Item	Road	Shape Length	Approx. Miles	Road Width	Sq Yds for Tack	Unit	Unit Quantities	Price per Unit	Extension			
EC	1	Bridge Deck Resurface	5,544	1.05	24.00	14,784							
		Resurface Bridge Deck #149 With Membrane (CC4 - County Road 28)					LS	1		\$0.00			
		Monument Replacement					EACH	1		\$0.00			
		TOTAL FOR ITEM									\$0.00		

										BID			
Group	Item	Road	Shape Length	Approx. Miles	Road Width	Sq Yards	Unit	Unit Quantities	Price per Unit	Extension			
EC	2	Clayton St from Shaffer Ave to Cul-De-Sac	422	0.08	22.00	1,320							
		Prep Cost (Mill)					LS	1		\$0.00			
		Asphalt Milling (2 inches)					SYS	1,320		\$0.00			
		Tack Coat					SYS	1,320		\$0.00			
		Joint Seal					LFT	422		\$0.00			
		220 lb/yd <sup>2</sup> HMA 12.5 mm, Surface, Type B, 58S-28					TON	146		\$0.00			
		#53 Gravel Shoulders					TON	200		\$0.00			
		TOTAL FOR ITEM									\$0.00		

Group	Item	Road	Shape Length	Approx. Miles	Road Width	Sq Yds	Unit	Unit Quantities	Price per Unit	Extension
EC	3	Bridge Deck Resurface	250	1.05	26.00	722				
		Resurface Bridge Deck #183 With Membrane (County Road 43 between County Road 16 and US 20)					LS	1		\$0.00
		220 lb/yd <sup>2</sup> HMA, Type B Surface 12.5 mm					TON	80		\$0.00
		Tack Coat					SYS	722		\$0.00
		Joint Seal					LFT	250		\$0.00
		Monument Replacement					SYS	1		\$0.00
		TOTAL FOR ITEM								

Group	Item	Road	Shape Length	Approx. Miles	Road Width	Sq Yds	Unit	Unit Quantities	Price per Unit	Extension
EC	4	Bridge Deck Resurface	250	1.05	26.00	722				
		Resurface Bridge Deck #206 With Membrane (County Road 33 between County Road 38 and County Road 40)					LS	1		\$0.00
		220 lb/yd <sup>2</sup> HMA, Type B Surface 12.5 mm					TON	80		\$0.00
		Tack Coat					SYS	722		\$0.00
		Joint Seal					LFT	250		\$0.00
		Monument Replacement					SYS	1		\$0.00
TOTAL FOR ITEM									\$0.00	

Group	Item	Road	Shape Length	Approx. Miles	Road Width	Sq Yds	Unit	Unit Quantities	Price per Unit	Extension
EC	5	Bridge Deck Resurface	250	1.05	26.00	722				
		Resurface Bridge Deck #210 (County Road 31 between County Road 138 and County Road 38)					LS	1		\$0.00
		220 lb/yd <sup>2</sup> HMA, Type B Surface 12.5 mm					TON	80		\$0.00
		Tack Coat					SYS	722		\$0.00
		Joint Seal					LFT	250		\$0.00
		Monument Replacement					SYS	1		\$0.00
TOTAL FOR ITEM									\$0.00	

Group	Item	Road	Shape Length	Approx. Miles	Road Width	Sq Yds	Unit	Unit Quantities	Price per Unit	Extension		
EC	6	Bridge Deck Resurface	250	1.05	26.00	722						
		Resurface Bridge Deck #351 (County Road 43 between County Road 44 and County Road 46)							LS	1		\$0.00
		220 lb/yd <sup>2</sup> HMA, Type B Surface 12.5 mm							TON	80		\$0.00
		Tack Coat							SYS	722		\$0.00
		Joint Seal							LFT	250		\$0.00
		Monument Replacement							SYS	1		\$0.00
TOTAL FOR ITEM										\$0.00		
Group	Item	Road	Shape Length	Approx. Miles	Road Width	Sq Yds	Unit	Unit Quantities	Price per Unit	Extension		
EC	7	ECL Speed Humps	5,000	0.95	24.00	13,334						
		Prep Cost (Mill)							LS	1		\$0.00
		Asphalt Milling (2 inches)							SYS	223		\$0.00
		220 lb/yd <sup>2</sup> HMA 12.5 mm, Surface, Type B, 58S-28							TON	60		\$0.00
		Pavement Message Marking, Paint, Lane Indication Arrow							EA	20		\$0.00
TOTAL FOR ITEM										\$0.00		
Group	Item	Road	Shape Length	Approx. Miles	Road Width	Sq Yds	Unit	Unit Quantities	Price per Unit	Extension		
EC	8	CCMG Full Depth Patching	0	0.00	24.00	1,224						
		CC 1: Full Depth Patching, Type B, 58S-28							TON	120		\$0.00
		CC 2: Full Depth Patching, Type B, 58S-28							TON	319		\$0.00
		CC 4: Full Depth Patching, Type B, 58S-28							TON	46		\$0.00
		CC 5A: Full Depth Patching, Type B, 58S-28							TON	23		\$0.00
TOTAL FOR ITEM										\$0.00		

BID												
Group	Item	Road	Shape Length	Approx. Miles	Road Width	Sq Yards	Unit	Unit Quantities	Price per Unit	Extension		
ALT	1	County Road 6 from County Road 9 to County Road 11	5,808	1.10	65.00	41,947						
		Prep Cost (Mill)							LS	1		\$0.00
		Asphalt Milling (2 inches)							SYS	41,947		\$0.00
		Tack Coat							SYS	41,947		\$0.00
		Casting, Manhole, Adjust to Grade							EA	5		\$0.00
		Casting, Inlet, Adjust to Grade							EA	3		\$0.00
		Casting, Water Valve, Adjust to Grade							EA	7		\$0.00
		Joint Seal							LFT	5,808		\$0.00
		220 lb/yd <sup>2</sup> HMA 12.5 mm, Surface, Type C, 58S-28							TON	4,615		\$0.00
		Line, Paint, Solid, White 4"							LF	12,479		\$0.00
		Line, Paint, Solid, Double Yellow 4"							LF	12,978		\$0.00
		Pavement Markings, Thermoplastic, White, Stop Bar, 24"							LFT	165		\$0.00
		Pavement Markings, Thermoplastic, White, Straight-Right Combo Arrow							EA	6		\$0.00
		Pavement Markings, Thermoplastic, White, Left Turn Arrow							EA	5		\$0.00
		Sawcut for Loop Detector and Sealant							LFT	1,800		\$0.00
Signal Detector Housing							EA	8		\$0.00		
#53 Gravel Shoulders							TON	600		\$0.00		
TOTAL FOR ITEM										\$0.00		

**Total EC 2025-1 \$0.00**

**TOTAL 2025-1 CCMG: \$ -**

2025-1 CCMG Paving Program

**Division 3:**

# Project Technical Specifications

For

**2025-1 CCMG Paving Program**

---

**OWNERS:**

ELKHART COUNTY, INDIANA, ACTING THROUGH  
IT'S BOARD OF COUNTY COMMISSIONERS  
ELKHART COUNTY HIGHWAY DEPARTMENT  
ENGINEERING SECTION  
610 STEURY AVENUE  
GOSHEN, IN 46528

---



Elkhart County Highway Department  
610 Steury Avenue, Goshen, Indiana 46528  
Phone: 574-534-9394 • Fax: 574-533-7103



**INDEX**

TP1 - GENERAL INFORMATION	4
TP2 - TIME OF COMPLETION	4
TP3 - UTILITIES	5
TP4 - BUY AMERICAN REQUIREMENT	6
TP5 - STORAGE OF CONTRACTOR'S EQUIPMENT, MATERIALS AND TEMPORARY OFFICES	6
TP6 - HAZARD COMMUNICATIONS PROGRAM	7
TP7 - ENVIRONMENTAL RESTRICTIONS	7
TP8 - RIGHT-OF-WAY CLEARING	7
TP9 - MAINTENANCE OF TRAFFIC	8
TP10 - CONSTRUCTION STAKING	9
TP11 - CONTRACTOR'S RESPONSIBILITY FOR MATCHING OLD WORK	10
TP12 - DUST AND AIR POLLUTION CONTROL	10
TP13 - CONTAMINATION PRECAUTION	11
TP14 - EARTHWORK	11
TP15 - DRAINAGE STRUCTURES	12
TP16 - DEWATERING	14
TP17 - PROOFROLLING	14
TP18 - COMPACTED AGGREGATE	15
TP19 - DISPOSAL OF UNSUITABLE MATERIAL	16
TP20 - RECORD DRAWINGS	17
TP21 - MANUAL ON UNIFORM TRAFFIC CONTROL DEVICES (MUTCD)	17
TP22 - COORDINATION CLAUSE	17
TP23 - EXISTING TRAFFIC CONTROL DEVICES	18
TP24 - SUBGRADE TREATMENT	18

TP25 - HMA PAVEMENTS	19
TP26 - INSPECTION AND TESTING	20
TP27 - MONUMENTS	20
TP28 - MILLING OPERATIONS	21
TP29 - MILLING OPERATIONS PREPARATIONS	23
TP30 - RESTORATION OF PAVEMENT MARKINGS	24
TP31 - TRAFFIC SIGNAL EQUIPMENT	27
TP32- GRINDING OPERATIONS	27
TP33 - GRINDING OPERATIONS PREPARATIONS	29
TP34 - BRIDGE DECK RESURFACING	30
TP35 - DRIVEWAY TRANSITIONS	32
TP36 - MAILBOX RESET	31
TP37 - SHOULDERS	32
TP38 - HOT POURED JOINT ADHESIVE	32
TP39 – MANHOLES, INLETS, AND WATER VALVE	34

## TP1 - GENERAL INFORMATION

**GENERAL**

The following Technical Provisions are in addition to the Indiana Department of Transportation 2024 "STANDARD SPECIFICATIONS", which Standard Specifications shall apply to this contract. Where the words "Standard Specifications" and also where reference consisting of a number or numbers are used, they shall be construed as referring to the Indiana Department of Transportation 2020 Standard Specifications and current supplemental specifications and standard detail drawings.

The term "State" as used in the Standard Specifications shall be deleted and replaced with the term "County".

The term "Engineer" as used in the Standard Specifications shall be the person, firm, or corporation named as such in the written Agreement between the OWNER and CONTRACTOR.

## TP2 - TIME OF COMPLETION

**GENERAL**

Work on this Contract shall not begin prior to notice to proceed. The Contractor shall begin on or after **April 28<sup>th</sup> 2025**, and shall complete all work no later than **October 6<sup>th</sup> 2025**.

This completion date is a 'fixed calendar date' as defined by INDOT Standard Specifications section 108

Determination and Extension of Contract Time for Completion and Failure to Complete on Time shall be in accordance with the Agreement and all applicable requirements of 108.08 and 108.09 respectively, and modified as follows.

If an intermediate date is specified for one or more of the items or phases of the contract, liquidated damages will apply for that particular item or phase as if the intermediate date specified for said item or phase is the conclusion of said portion of project or contract.

No extension of Contract Time shall be allowed for weather or changes in quantities placed.

Changes in Contract Time will only be considered if requested in writing by the Contractor in accordance with Article 10 of the General Conditions.

The Contractor shall notify the Owner at least two (2) weeks in advance of his intention to perform any Work on the project. The contractor shall give the owner/inspector updated schedules of work on a weekly basis or as the schedule changes. The Contractor shall also notify the appropriate agencies of his intention to close any County Road in connection with the project. See ROAD CLOSING REQUIREMENTS.

Note that "Road Construction Ahead" signage shall be installed prior to any other work, and shall be removed only upon final acceptance of the project or initial acceptance of the segment for paving packages. These signs shall be checked on a daily basis and promptly reset as needed.

Substantial completion of a road segment is defined as the full planned width of the final course of asphalt has been placed and is ready for traffic, shoulders have been applied, driveway approaches are completed, any required grading is complete, and final striping has been placed.

Final Inspection may be done on a per segment basis. When a particular segment is completed, a final inspection may be requested and final acceptance granted for that particular segment.

Final Acceptance of a road segment is defined as the full planned width of the final course of asphalt has been placed and is ready for traffic, shoulders have been applied, driveway approaches are completed, any required grading is complete, final striping has been placed, construction signs and construction debris removed, pre-final inspection punch list items have been completed and final inspection has been granted.

Project Completion will be assessed by the following criteria, the full planned width of the final course of asphalt has been placed and is ready for traffic, shoulders have been applied, driveway approaches are completed, any required grading is complete, final striping has been placed, construction signs and construction debris removed, pre-final inspection punch list items have been completed, final inspection has been granted and all contract line items are completed. Time extension may be granted on any work items added through change order or outside of contract.

## TP3 - UTILITIES

### **GENERAL**

The Contractor shall determine the location of all underground and overhead utility lines within the project limits. If proper clearances cannot be obtained, affected planned structures shall be placed as otherwise directed and approved by the adjacent utility representatives (and as accepted by the Engineer).

### **COORDINATION WITH UTILITIES**

The Contractor shall be responsible for utility property and services in accordance with 107.20 of INDOT's Standard Specifications. All of the permanent and temporary utility appurtenances in their present or relocated positions shall have been considered in the bid. No additional compensation will be allowed for any delays, inconvenience, or damage sustained by the Contractor due to any interference from the said utility appurtenances or the operations of

moving them.

The plan drawings include a list of names for the known companies that may have utilities located within the limits of construction in this contract. If any of these utilities are affected, it shall be the Contractor's responsibility to identify and coordinate with that utility.

The prime contractor shall be ultimately responsible for the completeness and promptness of utility location(s) for subcontractors. Multiple locations of the same facilities may be required throughout the project time.

#### TP4 - BUY AMERICAN REQUIREMENT

##### **GENERAL**

Buy American Requirements shall be in accordance with 106.01(c) of INDOT's Standard Specifications.

#### TP5 - STORAGE OF CONTRACTOR'S EQUIPMENT, MATERIALS AND TEMPORARY OFFICES

##### **GENERAL**

The Contractor will be permitted to store non-operating construction equipment, workmen's vehicles, materials and temporary offices within the limits of the Right-of-Way with approval from Owner.

In the event that the Right-of-Way is not available for storage, the Contractor shall procure an adequately secure operations site as an incidental item to the contract.

All areas within the limits of the Right-of-Way that are used by the Contractor for temporary storage of materials, non-operating construction equipment, workmen's vehicles and temporary offices, when no longer required for such purpose, shall be restored to their original condition by the Contractor at his own expense.

The Contractor shall not use property adjacent to the project Right-of-Way for storage, parking or any other use without prior approval from the property owner.

#### PROTECTION AND RESTORATION OF PROPERTY AND LANDSCAPE

The Contractor shall be responsible for preservation of all public and private property. All areas on the Right-of-Way that are used for storage of any kind shall be restored to their original condition when no longer required for that purpose. Generally, this shall comply with the requirements of Sections 107.14 and 107.19 of Standard Specifications.

## TP6 - HAZARD COMMUNICATIONS PROGRAM

### GENERAL

Pursuant to the latest requirement of OSHA the bidder is obligated to inform his employees concerning the health and safety hazards of chemical substance that may be required in the performance of this contract.

## TP7 - ENVIRONMENTAL RESTRICTIONS

### GENERAL

- (a) All trees or shrubs outside the construction limits shall not be disturbed.
- (b) Construction limit shall be defined as the Right-of-Way line unless otherwise shown on the plans.

### PERMITS

Regulatory permits for this project to be obtained by the OWNER currently are as follows:

- None

The CONTRACTOR is responsible for securing all other permits that may be required for this project in accordance with the Standard Specifications.

## TP8 - RIGHT-OF-WAY CLEARING

### GENERAL

Clearing right-of-way shall include the removal and/or trimming of all trees and brush within the right-of-way unless specifically identified on the contract plans to remain. Stumps shall be entirely removed and filled with sand.

Incidental to the work shall be the removal of any miscellaneous obstructions within the right-of-way.

The work shall include the removal of portions of existing pavement as indicated by plan details and/or within the construction limits or to the r/w line, whichever is greater.

It is the Contractor's responsibility to adequately inspect the site and clarify the intent of the project prior to submitting a bid.

## TP9 – MAINTENANCE OF TRAFFIC

### GENERAL

All signs and traffic control devices shall be in accordance with the Indiana Department of Transportation Standard Specifications and the Indiana MUTCD so as to provide continuous, safe, 2-way traffic at all times.

The Contractor shall be totally responsible for the maintenance of traffic. Maintaining of traffic shall be the non-delegable duty of the Contractor to fulfill each and every responsibility and to accept full liability. All applicable provisions of 107.12 shall apply to work being done under traffic.

Access to residential and business driveways within the project limits shall be maintained at all times. Temporary closure of driveway access may be allowed upon approval of the Engineer and adequate notification of the property owner. All driveways shall be accessible at the end of each work day. Stone, gravel or other temporary materials needed to make driveways accessible will not be paid for directly but will be included in the Maintenance of Traffic pay item.

Construction signs and barricades shall be as per INDOT standard sheets and shall be in sufficient condition for good functioning (i.e. visible, readable, reflective, etc.). The Contractor will be responsible for maintenance of traffic including all construction signs necessary or as directed by the Engineer for the duration of construction.

When necessary or as directed by the Engineer, the Contractor shall provide standard reflective barrels with approved weighting systems, flagmen, caution tape, temporary pavement markings, etc. Reflective barrels shall be placed to warn motorists of hazards. Maximum spacing of barrels shall be 30 ft.

The timing of any lane restrictions shall be subject to approval by the Engineer.

The Contractor shall keep lane restrictions to an absolute minimum, as reasonable in order to complete the work. When lane restrictions are necessary, the Contractor shall perform continuous work operations so as to lift the lane restrictions as soon as possible. Lane restrictions shall not remain in place while the Contractor is not actively working.

All other costs of maintaining traffic, as specified for in this contract, shall be paid for at the lump sum price bid for "Prep Cost", and such price shall include and be full compensation for all costs incurred by the Contractor for maintaining traffic, and as set forth in Sections 104.04 and 108.04 of the Standard Specifications.

The Contractor shall be responsible for safe driving of haul trucks, heavy equipment, etc. related to the project work, including subcontractors.

Temporary pavement markings shall be required before two-way traffic is allowed on a newly paved road; if more than one lane is present in the same direction, turn lanes or if previous pavement markings existed and removed before permanent markings are applied.

The Contractor shall give a 24 hr./day emergency phone number to the owner and to local law enforcement authorities, for the prompt response to project-related concerns during non-work hours.

Lane restrictions shall be during daylight hours only unless otherwise approved by the Engineer.

The Contractor shall coordinate the specific timing of the activation of any new signalization system, reopening, etc. When practical, the Contractor shall provide access through the site for emergency vehicle traffic.

Note that "Road Construction Ahead" signage shall be installed prior to any other work, and shall be removed only upon final acceptance of the project or initial acceptance of the segment for paving packages. These signs shall be checked on a daily basis and promptly reset as needed.

On roads that have an ADT of 5000 cars per day or greater, advance warning of road construction and / or closure shall be placed 1 week in advance of construction and detour route established. These roads will be noted on bid sheet.

## TP10 – CONSTRUCTION STAKING

### **GENERAL**

The Contractor shall provide construction layout/surveying under the direction of a licensed land surveyor for the improvements as shown in the project plans and specifications. The cost of this item shall be included in the cost of other items and shall include, but may not be limited to the following:

Locate existing bench marks and verify level circuit to check elevations. Set new bench marks (if needed) every 500 feet. Bench mark data sheets shall be provided to the project Engineer.

Stake right-of-way as needed.

Stake all easement lines.

Preserve and perpetuate existing property corners, which are at risk from construction



operations. (This item must be performed under the direct supervision of a licensed surveyor.)

Field notes shall be kept in standard field notebooks supplied by the Contractor in a clear, orderly and neat manner consistent with standard engineering practices and procedures. The field books shall be available for inspection by the Engineer at all times and shall become the property of the Owner on completion of the work.

The supervision of the Contractor's construction staking personnel shall be the responsibility of the Contractor and any errors resulting from the operations of such personnel shall be corrected at the expense of the Contractor and at no additional cost to the Owner.

The Engineer may check the accuracy of the staking as necessary, but will assume no responsibility for the accuracy of the layout or the final result of construction accuracy.

**When "laying out" the project, an Elkhart County representative will be available to go over transition areas and "start / stop" locations.**

Surveying pertaining to existing right-of-ways and monument perpetuation shall be performed under the direction of a Land Surveyor licensed in the State of Indiana.

## TP11 - CONTRACTOR'S RESPONSIBILITY FOR MATCHING OLD WORK

### GENERAL

Where new pavement is to be fitted to existing pavement, the Contractor shall check all leading dimensions, elevations and conditions in the field and report any errors or discrepancies to the Engineer and assume responsibility for their correctness and the fit of new parts to old. If such parts do not fit properly, the Contractor shall make and pay for such alterations or new parts as may be necessary to assure proper fits and connections meeting the approval of the Engineer. Transition from new pavement to existing, shall be less than 1/2 inch.

All adjoining asphalt surfaces, including but not limited to, cross roads, passing blisters, driveways, shall be cut full depth or milled 1½ inch minimum to provide a smooth transition. Transition joints shall be constructed in accordance with Elkhart County's TRANSVERSEJOINT TRANSITION DETAIL. Any damage to edge will be removed prior to paving. Payment shall be included in prep cost line item.

## TP12 - DUST AND AIR POLLUTION CONTROL

### GENERAL

Provision shall be made for prompt removal from traveled roadways of all dirt and other materials that have been deposited thereon by operations associated with the project, whenever the accumulation is sufficient to cause the formation of dust or mud, interfere with drainage, damage pavements, or create a traffic hazard. Construction methods and means shall be employed to keep flying dust and air pollution to a minimum. Provisions shall be made for the control of dust on the project and on the roads, streets and other areas affected by the project wherever traffic or buildings or construction materials are affected by such dust. The materials and methods used for dust control shall be subject to approval by the Engineer. Pulverized roads within the Paving Program shall have grade watered to minimize dust. The cost of controlling dust and air pollution shall be included in the costs of other pay items and no additional payment will be made.

### TP13 – CONTAMINATION PRECAUTION

#### **GENERAL**

Contractor shall take all precautions to avoid the spillage of construction-related liquids and fuels during the project. All portable stationary fuel tanks shall have secondary containment.

### TP14 - EARTHWORK

#### **GENERAL**

- (a) This work shall consist of all earthwork required for the completion of the project as detailed on the plans and in the specifications. This item includes excavation, embankment construction, hauling, disposal and/or compaction of all material not being removed under some other item which is encountered within the limits of the work and also from intersecting entrance approaches beyond the Right-of-Way limits necessary for the construction of the roadway in accordance with the Specifications and in reasonably close conformance with the lines, grades, thickness and typical cross section shown on the plans or as directed.
- (b) Excavation for culverts, ditches, sewers, tunnels, and other approach structures will not be paid for directly, but the cost thereof shall be included in the cost of other pay items. Removal and disposal of piles of broken concrete and similar debris located on the Right-of-Way shall be included in the cost of earthwork. Where surplus material is suitable for use in the roadway or bridge approach embankment, it may be used as allowed by the Engineer.
- (c) Borrow shall consist of approved material required for construction of embankments. No direct payment will be made for borrow required for

embankment construction in accordance with lines, grades and typical cross sections specified.

- (d) The work shall include salvaging topsoil and replacement of topsoil for top dressing areas to receive sod or mulch seeding.

## CONCRETE PAVEMENT REMOVAL

Removal of pavement shall consist of the removal and satisfactory disposal of portland cement concrete pavement; portland cement concrete surface with its base; or the total of any combination of base, binder, and surface course of any pavement on a portland cement concrete base, including the base. Each complete pavement section removed, regardless of thickness and composition will be considered as a separate item and paid for as such when removed. Pavement removal shall include only the removal and disposal of existing public road, driveway or street and alley pavement as required for the planned construction. Curb removal shall include curb that is separate from the pavement or removed separately. Integral curb that is removed with the adjacent pavement shall be paid for as pavement removal. Prior to performing the work of pavement removal at locations indicated on the plans or where directed, concrete pavement to be removed shall be cut with a power driven concrete saw along designated lines. Sawing shall be such that any portion of the pavement to remain in place will not be damaged. Any portion that is damaged or removed outside the designated lines shall be replaced with no additional payment. Sawing of pavement to be removed will not be paid for directly, but shall be included in the cost of pavement removal.

If no Pay Item has been established in the Proposal for Concrete Pavement Removal, and such work is necessary to perform the above, such work shall not be paid for directly, but shall be included in the costs of other pay items.

## CONSTRUCTION

Excavation and embankment methods and testing shall conform to the INDOT standard specifications.

## TP15 - DRAINAGE STRUCTURES

### 1. GENERAL

- (a) All new structures shall comply with plans and shall be installed to the elevations shown on the plans or as otherwise determined by the Engineer.
- (b) Construction of all new inlets involving existing structures shall be accomplished such that the existing pipe structure is not damaged.

- (c) Where a new casting is to be fitted to an existing catch basin or an existing casting is to be fitted to a new inlet, the Contractor shall check all dimensions and conditions in the field and shall assume responsibility for their correctness and fit.
- (d) The cost of removal or modification of existing drainage structures as shown on the plans shall be included in the contract unit prices for the new structure items except as otherwise noted.
- (e) All existing structures damaged during construction shall be replaced with no additional payment.
- (f) At the connection of a pipe to a concrete structure, gasket connections shall be employed.
- (g) Pipes shall extend through walls, a sufficient distance, to allow for placement of the gasket connection.
- (h) Field constructed connections to structures, new or existing, shall be core drilled.
- (i) Mortar collars shall be placed on inside and outside of pipe installed in all structures.
- (j) Flow lines shall be poured in all structures when required.

## 2. CLEAN-UP

- (a) Clean-up shall be in accordance with sub-section 104.08 of the State Specifications.
- (b) No payment will be made for clean-up.

## 3. SEWER PIPE AND APPURTENANCES

- (a) DESCRIPTION – this work shall consist of the construction or reconstruction of sanitary sewer, storm sewer and appurtenances in accordance with specifications section 715 and in reasonably close conformance with the lines and grades shown on the plans or established by the Engineer
- (b) MATERIALS – Materials shall be in accordance with State Specifications Section 715 and details shown on the drawings.

- (c) GENERAL REQUIREMENTS – Manholes, inlets and catch basins shall comply with Section 720 of the State Specifications. Risers shall not exceed two risers per structure. Manholes, inlets and catch basins shall be done in accordance with the details shown on the drawings.

#### 4. BASIS OF PAYMENT

- (a) The accepted quantities for each class and diameter of sewer pipe specified will be paid for at the contract price per lineal foot complete in place. The accepted quantities of manholes, clean-outs, pipe end sections, inlets, catch basin and drywells will be paid for at the contract unit price each in place. The payment shall be full compensation for furnishing and installing all materials, labor, excavation, backfilling, pavement removal, testing, dewatering, compaction and all appurtenances.

#### TP16 - DEWATERING

##### **GENERAL**

No pay item will be provided for dewatering. Any expenditure for equipment, labor, etc. to provide dewatering of an excavation should be included in the price of the other line items.

The Contractor shall arrange for dewatering discharge outfalls. Outfalls shall be acceptable to the Owner, the Elkhart County Drainage Board and the Indiana Department of Natural Resources.

#### TP17 - PROOFROLLING

##### **GENERAL**

- (a) Proof rolling of the natural ground surface shall be in accordance with 203.26 within all areas where new fill will be placed. Any soft soils encountered during the proof rolling operations, which will not readily compact, shall be removed and replaced with Structure Backfill to an elevation two (2) feet above the ground water level, if ground water is encountered. Otherwise backfilling shall be accomplished in accordance with 203.09. The Contractor shall schedule a proof roll with the Owner's representative 24 hours in advance of all proof rolls. A weight ticket will be required for the truck performing the proof roll, showing a minimum gross weight of 68,000 lbs. for a tri-axle or tandem axle truck. No quad axle trucks will be allowed unless the fourth axle is able to be lifted from the surface for the test, and is.

**1. PAYMENT**

- a) No direct payment will be made for proof rolling. The cost of this work shall be included in bid price of other items.

**TP18 – COMPACTED AGGREGATE****GENERAL**

- (a) All compacted aggregate shall be paid under this item regardless whether used as base course for the mainline, as base course for the shoulders, as base course for approaches or as temporary surface.
- (b) All compacted aggregate shall be Compacted Aggregate, No. 53, in accordance with Section 300 – Aggregate Bases.
- (c) Aggregate to maintain temporary access to driveways may be salvaged from existing onsite gravel roads, drives and shoulders.
- (d) It shall be the Contractor's responsibility to verify that subgrade elevations are in agreement with the plan/profile.

**1. CONSTRUCTION**

The compacted aggregate shall be constructed in accordance with INDOT Section 300 – Aggregate Bases.

Existing Subgrade (or Previously Constructed Subbase) – Prior to constructing the compacted aggregate, the subgrade shall be cleaned of all foreign substances and shall contain no frozen material. The Subgrade shall receive 6" subgrade treatment in accordance with the Standard Specifications and as directed by the Engineer. The first 6" below the pavement structure subgrade shall be compacted to at least 100% of dry density, as per AASHTO T 99. Compaction shall not be less than 100% of Standard Proctor as per ASTM D 698. It shall be inspected by the Engineer or his representative for adequate compaction and surface tolerances. Ruts or soft, yielding spots having inadequate compaction shall be corrected to the satisfaction of the designated representative.

The compacted aggregate material shall be placed in layers of uniform thickness with an approved spreader.

Layer thickness generally shall not exceed 5 inches after compaction. When vibrating or other approved types of special compacting equipment are to be used, approval may be given for increasing the permissible thickness of layers, provided

the ability of such equipment to achieve acceptable compaction to the full layer depth is demonstrated. When the course is constructed in more than one layer, the previously constructed layers shall be cleaned of loose and foreign matter. The water content of the material shall be maintained during placement at the optimum percentage (1 – ½%) as determined by ASTM D 1557.

Compaction – While at optimum moisture (1 – ½%) the compacted aggregate shall be compacted with equipment capable of obtaining the desired density to the full depth. The rolling shall continue until the base is compacted to not less than 100% of the maximum dry density as determined in accordance with AASHTO T99.

Finishing – The surface of the compacted aggregate shall be finished by blading or with automated equipment especially designed for this purpose and rolled with a steel-wheeled roller. In no case will thin layers of fine materials be added to the top layer of the base course in order to meet the grade.

Surface Finish Tolerances – The surface of the completed crushed stone base shall not show any deviation in excess of ½ inch when tested with a 12 foot straight edge. The completed thickness of the base shall be within ½ inch plus or minus of the thickness indicated, and the average thickness shall not be less than the design thickness.

Maintenance – The base shall be maintained in a condition that will meet all specification requirements until the work is accepted.

## 2. PAYMENT

Payment will be made at the unit price as indicated below:

<b>Pay Item</b>	<b>Pay Unit</b>
Compacted Aggregate, No 53.	Ton

### TP19 - DISPOSAL OF UNSUITABLE MATERIAL

#### GENERAL

- (a) No temporary Right-of-Way has been provided on this contract for disposal of unsuitable material. The disposal of any peat and/or any other unsuitable soil that might be encountered throughout the length of the project shall be in accordance with all applicable requirements of 203.12.
- (b) Excess peat or any unsuitable material left over after placement as set out in 203.12 shall be disposed of outside the Right-of-Way with no additional payment.

- (c) Excess material may be utilized as “topsoil” where appropriate.

## TP20 – RECORD DRAWINGS

### GENERAL

Record Drawings shall be required for all major projects.

Record Drawings shall be required for minor projects if they include, but not limited to, the following elements: change in road elevations, profile, alignment, small structure improvement, intersection improvement, drainage pipe and structures.

The Contractor shall provide the Owner with two (2) neatly prepared and reproducible sets of record drawings and two (2) complete sets in PDF format on a CD or DVD.

### MINIMUM RECORD DRAWING REQUIREMENTS

Record drawings shall include the following, but not be limited to:

- 1) Installed structure locations (including GPS coordinates) and elevations
- 2) Elevations of installed improvements at regular intervals not to exceed 50 feet, i.e., curb and gutter, pavement centerline, swales and ditches, etc.
- 3) Detention/Retention basin elevations with constructed capacity
- 4) Any other newly constructed or reconstructed features pertinent to the project

Record drawing preparation shall be incidental to the contract.

## TP21 - MANUAL ON UNIFORM TRAFFIC CONTROL DEVICES (MUTCD)

### GENERAL

Wherever in the Contract Documents reference is made to the Manual on Uniform Traffic Control Devices, MUTCD, it shall be interpreted to mean the 2011 Indiana Manual on Uniform Traffic Control Devices with revisions 1, 2 & 3.

## TP22 - COORDINATION CLAUSE

### GENERAL



Contractor shall coordinate the work on this project with any other public works projects that may be taking place within the vicinity of the project site, or that are seen to, or are expected to, have an effect on this project or that this project has on another. This includes coordination with projects funded by Elkhart County, neighboring counties, municipalities, utilities or INDOT.

### TP23 - EXISTING TRAFFIC CONTROL DEVICES

#### GENERAL

- (a) This work shall consist of the removal and delivery to the County of all roadway signs and delineators that are to be removed and not reused in this contract. These items are to be delivered to the location specified by the Engineer. This work will not be paid for separately, but shall be included in the cost of other items.
- (b) Signs not required to be removed, or are planned for reuse, that are damaged by the Contractor shall be replaced by the Contractor.
- (c) All existing regulatory signs shall be maintained at all times during construction. For questions that should arise, the Engineer will be notified.
- (d) For all other signs that are to be disturbed, the County will be notified as to the reinstallation of these signs.
- (e) All existing traffic signals, masts, poles and other hardware if removed must be salvaged and maintained in good condition by the Contractor. The County has salvage rights for all removed items if not reused in the course of constructing this project.

### TP24 – SUBGRADE TREATMENT

#### GENERAL

Areas with inadequate soils may require subgrade treatment. These areas will be identified by the Engineer during the course of the project through proof rolls or other means. The Engineer will direct the Contractor in an appropriate treatment that may consist of excavation and replacement of the inferior soils with No. 2 Compacted Aggregate, No. 53 Compacted Aggregate, Geogrid, or combinations of some or all of the above.

#### MATERIALS

The materials used shall conform to the Geogrid specification as listed in this document. Aggregate shall conform to the INDOT specifications in effect at the time of bidding for the

aggregate classes identified.

#### CONSTRUCTION

Remove the soil in areas designated by the Engineer, to the depth specified. Place aggregate and/or geogrid as directed.

#### BASIS OF PAYMENT

Compaction and/or placement of the materials used for subgrade treatment shall be included in the unit price of those items.

<b><u>Pay Item</u></b>	<b><u>Pay Unit</u></b>
No. 2 Compacted Aggregate for Subgrade Treatment	TON
No. 53 Compacted Aggregate for Subgrade Treatment	TON
Geogrid for Subgrade Treatment	SYS
Excavation for Subgrade Treatment	CYS

### TP25 – HMA PAVEMENTS

#### 1. GENERAL

Mainline and shoulder pavements shall conform to INDOT Standard Specifications section 402. PG Binder grades used in each mixture type shall conform to section 402.04. Pavements shall be supplied by a certified HMA plant in accordance with ITM 583.

#### 2. QUALITY CONTROL

The HMA shall be transported and placed according to the Quality Control Plan QCP submitted by the contractor according to ITM 803. Quality Control Plan shall be submitted to the Engineer 15 days prior to the placement of HMA.

During the pavement operation, the owner, the contractor, or the supplier of the HMA reserves the right to stop paving when a problem is identified. This includes test results from the Transtech PQI 380 indicating insufficient density readings as performed by Engineer.

#### 3. ACCEPTANCE OF MIXTURES

Design mix formula shall be submitted to the engineer for approval one week prior to use. Mixes shall be accepted by a Type D certification in accordance with section 916. Type D certification to include air voids and binder content.

The Engineer will select random locations for verification sampling. A verification sample will be at the auger of the paving device or, if determined by the engineer, a truck sample in accordance with AASHTO R 97. Samples will be tested by owners representative to verify Air voids, binder content, and mix gradation.

#### 4. CONSTRUCTION REQUIREMENTS

Equipment for the HMA operations shall be in accordance with section 409 and shall be listed in the QCP. The contractor is responsible for the paving layout and roller pattern to achieve the specified density requirements.

#### 5. DENSITY

For mainline paving, the density shall be determined using cores from two random locations selected by the engineer for a quantity not to exceed 600 ton of surface or 1000 ton of base or intermediate placed. Cores shall be drilled at each location where mix is placed every day work is performed. The cores shall be taken in accordance with ITM 580. The contractor is to drill the cores and immediately submit them to the Engineer for testing. Acceptance is based on maximum specific gravity and shall be within 92-96% Maximum Specific Gravity. Acceptance is based on three successive core tests calculated as an average. Average will be of current, previous and proceeding cores if available. Any density less than 90% will be considered deficient, and additional cores may be necessary to determine areas for removal.

Cores shall produce a uniform sample 6.00 ±0.25 in. Cores shall be cleaned, dried, and refilled with either HMA of similar or smaller size. Core hole shall be filled the same day as it is cut.

### TP26 – INSPECTION AND TESTING

#### GENERAL

##### 1. LABORATORY INSPECTION AND TESTING

- (a) All collection, laboratory inspection and testing of materials shall be performed as required under Article 106.02 of the Standard Specifications except as modified herein. It is the responsibility of the Contractor to see that all work is performed as required herein. The collection, laboratory inspection and testing of materials shall be performed by an independent testing laboratory.
- (b) The minimum number of samples and/or tests will be in accordance with INDOT's "Manual for Frequency of Sampling and Testing and Basis for Use of Material" unless superseded by the Technical Provisions and Supplementary Specifications for this project. This manual is available for review at INDOT's Office of the Division of Materials and Tests.
- (c) The cost of this work shall be included in the bid price of other items.
- (d) The Engineer, or the Engineer's Authorized Representative, may require that collection, laboratory inspection and testing of materials be performed in addition to the minimum number of tests required as described above. A written order will be provided to the Contractor requesting the additional work. Payment for the additional collection, laboratory inspection and testing of materials will be made either by change order or under the item allowance for Inspection and Testing if included in the contract. All test results shall be given to the owner/inspector in a timely manner.
- (e) For paving packages only, Contractor will be required to take one sample per Mix Design of asphalt from behind paver for EACH road in excess of 800 total tons total.

## TP27 – MONUMENTS

### GENERAL

**Monuments are the responsibility of the contractor on all segments awarded within the Paving Contract. Maintaining location and preservation, visibility, and adjusting to new grade shall be the responsibility of the contractor. If a monument will need to be replaced due to change in profile, where a riser will not suffice, or, at the direction of Owner, a line item will be supplied in the bid tab to accommodate the replacement item.**

**Existing monuments shall not be disturbed unless directed by Engineer. Any monument disturbed through the construction process, shall be replaced at the Contractors expense including cost of monument.**

- (a) On roads that will be milled and repaved, all monuments will remain in place and the contractor will work around them.
- (b) On road sections that will be completely removed, the contractor will be required to leave the monuments in place unless the profile of the road will be changed. The owner/inspector will make the decision if the monument will need to be replaced or adjusted.  
If the monument is to be replaced, the contractor will be required to replace the monument at the cost of the bid item. The replacement will include the removal and disposal of the old monument and all associated materials. The monument must be replaced by a licensed surveyor or by technicians working under the direct supervision of a licensed surveyor.
- (c) Monuments to be used must be approved by the Elkhart County Surveyor.
- (d) Monuments will be marked before work begins on each section of road by Elkhart County Surveyor.
- (e) Extensions may be used if needed to adjust existing monument to new grade. Elkhart County will supply risers for adjusting of monuments.
- (f) Final elevation of the monument shall not exceed finished elevation of asphalt and shall be recessed no greater than 1/2 inch.

## TP28 – MILLING OPERATIONS

### GENERAL

This item shall include the milling and removal of milled materials, to the depth indicated on the plans.

HMA Millings are the property of the County unless noted otherwise. The Contractor shall transport millings to a location designated by the County, if Elkhart County chooses to retain or use millings. The cost of transporting the millings shall be included in the cost of Milling Operations if millings are to be retained or used and will be noted prior to bidding.

The existing pavement shall be removed to varying depths in a manner that shall restore the pavement surface to a uniform longitudinal profile and cross-section while preserving curb and/or gutter if present. Removal shall be to the depth and cross slope as specified in the contract or as directed by the Engineer. If an independent grade reference is required, it shall be designated in the contract and shall be established by the Engineer. All new pavements shall have 2% slopes.

Longitudinal pavement edge drop-offs of two (2) inches or greater shall not be left at the end of the workday without proper traffic control devices in place or otherwise addressing the condition such that there is no hazard to motorists. Traffic control devices shall be in accordance with the Manual of Uniform Traffic Control Devices (MUTCD) latest edition. There shall be no additional compensation for providing traffic control devices or otherwise addressing the pavement edge drop-off condition such that there is no hazard to motorists.

1. Tack shall be placed on clean surface prior to paving for surface layer application.
2. All work shall be performed during daylight hours.
3. All work shall take place Monday through Friday excluding holidays.
4. Asphalt placement shall begin within 48 hours of the commencement of the milling operation and continue each work day until completed. For multiple segments greater than 1 mile, a time extension may be granted prior to paving, so prep may be completed. Extension time must be approved by Engineer and paving must continue until segment is completed to avoid damages.
5. Paving / Milling may occur on Saturdays with notification to Elkhart County Highway Inspector.
6. A Six thousand dollar (\$6,000) per sub-group penalty will be assessed to the contractor for locations where asphalt placement is not commenced within 48 hours after milling. Unless authorized by ENGINEER (SEE ITEM 4).
7. Contractor to provide Model and Type of Milling Machine to be used on this project or specialized subcontractors name to be utilized.
8. Driveways shall be transitioned to meet at present elevation, as outlined in TP39.

9. All Pavement markings (including striping, stop bars, RR Crossings, pedestrian walkways etc.) disturbed by construction shall be replaced by contractor. Payment shall be as outlined in TP 30.
10. # 53 gravel shoulders shall be applied ASAP to avoid unsafe conditions if specified. Payment is to be made per line item. Gravel shoulders shall be two feet wide, and shall not exceed two feet. Shoulders may consist of minimal millings.
11. All adjoining asphalt surfaces, including but not limited to, cross roads, passing blisters, driveways, shall be cut full depth and material removed or milled 1½ inch depth and 36 inches width minimum across the entire width of the pavement to provide a smooth transition. Any damage to edge will be removed prior to paving. Payment shall be included in prep cost line item.
12. All gravel roads encountered shall have a 100 foot asphalt approach installed.
13. Pavement markings (including striping, stop bars, RR Crossings, pedestrian walkways, etc.) shall be replaced by contractor. Payment shall be included in prep cost line item.
14. Monuments are to be preserved and adjusted as outlined in TP27.
15. Bid shall include all costs for milling including passing blisters, driveway transitions, intersection radius, pavement marking restoration, etc.

## TP29 MILLING OPERATIONS PREPARATIONS

### GENERAL

This item includes all work required to prepare for milling and paving operations, as well as all work required to complete the project and return the construction area to an acceptable completed project, free of any defects or debris.

All work required to complete the sub-group listed on the bid tab, and are not included in other bid items, shall be included in this item. This includes the work items listed below as well as other incidental work that may be listed within other specifications and any other work items required to complete the project.

Work shall include, but not be limited to, the following:

- The removal of existing pavements by milling, in close conformity with the lines, grades, and cross-sections shown in the contract, specified on bid tab or as designated by the Engineer.

- The transporting of millings to a designated area as indicated.
- All loose material shall be removed to the greatest extent practical from the milled surface by thoroughly sweeping with a power broom or other approved equipment.
- The saw-cutting or milling of transitions to driveway approaches, cross streets or any other surface to be transitioned from existing to new pavement.
- All gravel drives must have taper with #53 Limestone
- Construction staking as outlined in TP10 and removal of staking upon completion of segment.
- Record drawing preparation and submittal if required.
- Inlet protection if structures are within the construction limits.
- Restoration of **ALL DISTURBED** pavement markings, applied as outlined in TP30.
- Any gaps remaining between the new pavements and existing earth must be filled in with topsoil. This application will be needed on milled roads in subdivisions without curb.
- Placement and removal of all traffic control associated with the milling process and as outlined in TP9 Maintenance of Traffic.
- Removal of all construction debris generated upon completion of the segment.
- All Cul-Da-Sacs that include any organics, trees, and topsoil, shall be excavated 6 inches below pavement, place no 53 aggregate, and cover the rest with hot mix asphalt.

**Pay Item**  
Prep Cost

**Pay Unit**  
LSUM

TP30 – RESTORATION OF PAVEMENT MARKINGS

**GENERAL**

**ALL PAVEMENT MARKINGS DISTURBED DURING CONSTRUCTION SHALL BE REPLACED AT PRECONSTRUCTION LOCATIONS, WHICH INCLUDES BUT NOT LIMITED TO STRIPING, STOP BARS, RR CROSSINGS, AND PEDESTRIAN WALKWAYS.**

## 1.0 Description

This specification covers thermoplastic, latex based traffic line paint and glass beads suitable for use as retro reflective pavement markings on bituminous or PCC pavement.

1.1 If road does not have edge markings and has an ADT of 5000 or more, edge lines must be installed as well. Road to have edge lines will be determined by Engineer and noted prior to bidding.

## 2.0 Materials

### A. Paint

Use white or yellow paint that is specifically manufactured for use on traffic markings. The paint must comply with volatile organic compound (VOC) requirements, be lead and other toxic heavy metal free, and exhibit the following qualities:

1. The non-volatile portion of the vehicle shall be composed of a 100% acrylic-polymer as determined by infrared spectral analysis.
2. Yellow and white paint shall have a minimum of 60% solids by volume.
3. The paint shall have a minimum of 60% and a maximum of 62% pigment by weight.
4. Dry-Opacity: A contrast ratio of not less than 0.96 when the paint is applied with a 0.015 in. film applicator. Dry Opacity will be determined according to Method 4121, Federal Test Method Standard No. 141a. Apply the paint to the chart specified in Section 1.1 of Method 4121.
5. Daylight Directional Reflectance of the white paint shall not be less than 85% as determined in accordance with ASTM E 1347 using the 45/0 illumination.
6. Color Match: Yellow paint shall match Federal Standard 595 color number 33538 tested in accordance with ASTM D 1729 with the daylight illumination represented by CIE Illuminant D75 or D65. White paint shall not exceed a yellowness index of 12 when tested in accordance with ASTM D 1925.
7. Titanium Dioxide Content: Yellow paint shall contain a maximum of 0.2 lb/gal rutile titanium dioxide. White paint shall contain a minimum of 1 lb/gal rutile titanium dioxide. Determine the titanium dioxide content using the aluminum reduction method of ASTM D 1394. **Drying Time:** The paint shall dry to a no tracking condition in no more than 90 seconds. The no tracking condition shall be determined by actual application on the pavement at a wet film thickness of 0.015 in. with white or yellow paint covered with glass beads at a rate of 6 lb/gal. Pavement temperatures shall be between 60 and 100° F and under all humidity conditions providing that the pavement is dry. The no tracking time shall be determined by passing over the paint line 90 seconds after paint application, in a simulated passing maneuver at a constant speed of 30 to 40 mph with a passenger car. A line showing no visual deposition of the paint to the pavement surface when viewed from a distance of 50 feet from the point where the test vehicle has crossed the line shall be considered as showing no tracking.

### B. Glass Beads

Reflective glass beads for use in the composition and for drop-on shall conform to the



following requirements:

1. The glass beads shall be colorless, clean, and transparent, free from milkiness or excessive air bubbles, and essentially free from surface scaring or scratching. They shall be spherical in shape and at least 70% of the glass beads shall be true spheres when tested in accordance with ASTM D 1155.
2. The refractive index of the beads shall be a minimum of 1.50 as determined by the liquid immersion method at 25 degrees Celsius true.
3. The silica content of the glass beads shall not be less than 60%.
4. The glass beads shall be coated with a moisture resistant coating and an adhesion promoting coating which is compatible with the paint being used, shall remain free from clusters, and shall flow freely from dispensing equipment.
5. The glass beads shall have the following grading when tested in accordance with AASHTO M-247 FOR TYPE 1

<u>US Standard Sieve</u>	<u>Mass % Passing</u>
No. 20	100
No. 30	75-95
No. 50	15-35
No. 100	0-5

**C. Thermoplastic Pavement Markings**

All linear pavement markings, stop bars, symbols, or words displayed on pavement that need replacement, must be replaced with thermoplastic and must follow the current INDOT Specification.

Application shall be per INDOT Specification Methods.

**ALL PERMANENT PAVEMENT MARKINGS SHALL BE RESTORED WITHIN 14 DAYS AFTER COMPLETED PAVING OF THE ROAD SEGMENT.**

<b><u>Pay Item</u></b>	<b><u>Pay Unit</u></b>
Linear Pavement Markings, Paint, 4"	LFT
Linear Pavement Markings, Thermoplastic, 4"	LFT
Linear Pavement Markings, Thermoplastic, Gore, 8"	LFT
Pavement Markings, Thermoplastic, White, Stop Bar, 24"	LFT

Pavement Markings, Thermoplastic, White, Arrow, Turn

EA

**TP31 – TRAFFIC SIGNAL EQUIPMENT**

Contractor shall replace detector housings and detection loops per INDOT Standard Specifications, the Elkhart County Street Standards, Appendix D, and the attached plans. All necessary signal wire, signal conduit, couplings, and labor necessary to connect old loop detection equipment to new detector housings and loops, and necessary work to provide a full functioning actuated traffic signal shall not be paid separately but will be included in the cost of other items.

**Pay Item**

**Pay Unit**

Sawcut for Loop Detector and Sealant  
Signal Detector Housing

LFT  
EA

**TP32 – GRINDING OPERATIONS  
GRIND & PAVE**

**GENERAL**

This item shall include the grinding and profiling of milled materials.

The existing pavement shall be reclaimed to a consistent depth in a manner that shall restore the pavement surface to a uniform longitudinal profile and cross-section. If an independent grade reference is required, it shall be designated in the contract and shall be established by the Engineer. All new pavements shall have 2% slopes.

Longitudinal pavement edge drop-offs of two (2) inches or greater shall not be left at the end of the workday without proper traffic control devices in place or otherwise addressing the condition such that there is no hazard to motorists. Traffic control devices shall be in accordance with the Manual of Uniform Traffic Control Devices (MUTCD) latest edition. There shall be no additional compensation for providing traffic control devices or otherwise addressing the pavement edge drop-off condition such that there is no hazard to motorists.

Gradation of reclaimed asphalt shall have a particle size of which 97% will pass through a 2” sieve.

Work shall include, but not be limited to, the following:

1.
  - a. Contractor to reclaim/grind asphalt in place 22 - 24 feet wide and to a depth sufficient to cut through all asphalt and gravel base. The grinding

- 
- operation should penetrate 1-2 inches into the sub-surface layer (clay or other material layer). Elkhart County Highway, at their discretion, may spread gravel or other material over the asphalt before grinding commences. The schedule for grinding must be approved by the Engineer prior to commencement of the operation.
- b. All roads which are to be reclaimed shall be reclaimed 1 foot wider than proposed road width for each lane and an additional prep of 1 foot for shoulders for each lane.
  - c. A pad foot roller shall be used immediately behind the grinder on entire area recycled and/or if fill areas are greater than 8 inches, pad foot roller shall make 6 cycles on all reclaimed areas.
  - d. Contractor shall grade material behind the pad foot roller to a 2% slope.
  - e. A vibratory roller shall be used over entire area until suitably compacted for paving.
  - f. Tack shall be placed prior to paving for intermediate and surface layer applications.
3. All work shall be performed during daylight hours.
  4. All work shall take place Monday through Friday excluding holidays.
  5. Asphalt placement shall begin within 48 hours of the commencement of the grinding operation and continue each work day until completed. For multiple segments greater than 1 mile, a time extension may be granted prior to paving, so prep may be completed. Extension time must be approved by Engineer and paving must continue until segment is completed to avoid damages.
  6. Elkhart County will provide the material for any necessary profile improvements. The time constraints will be adjusted for these circumstances on a case by case basis.
  7. Paving / Grinding may occur on Saturdays with notification to Elkhart County Highway Inspector.
  8. If rain is imminent, and forecasted, grinding of roads will be at the discretion of Engineer.
  9. A Six thousand dollar (\$6,000) per sub-group penalty will be assessed to the contractor for locations where asphalt placement does not commence within 48 hours after grinding. Unless authorized by ENGINEER (SEE ITEM 5).
  10. Contractor shall provide Model and Type of Grinding Machine to be used on this project or specialized subcontractors name to be utilized to Engineer prior to commencement of grinding.
  11. Driveways shall be transitioned to meet at present elevation, as outlined in TP34.
  12. Pavement markings (including striping, stop bars, RR Crossings, pedestrian walkways, etc.) shall be replaced by contractor. Payment shall be included in prep cost line item.

13. # 53 gravel shoulders shall be applied ASAP to avoid unsafe condition. Payment is to be made per line item. Gravel shoulders shall be two feet wide, and shall not exceed two feet. Shoulders may consist of minimal millings.
14. All adjoining asphalt surfaces, including but not limited to, cross roads, passing blisters, driveways, shall be cut full depth or milled 1½ inch minimum to provide a smooth transition. Transition joints shall be constructed in accordance with Elkhart County’s TRANSVERSEJOINT TRANSITION DETAIL. Any damage to edge will be removed prior to paving. Payment shall be included in prep cost line item.
15. All gravel roads encountered shall have a 100 foot asphalt approach installed.
16. Monuments are to be preserved and adjusted as outlined in TP27.
17. The cost of removing and replacing soft and yielding areas shall be included in the cost of other pay items in this section
18. Bid shall include all costs for grinding passing blisters, driveway transitions, intersection radius, pavement marking restoration, etc.

**Pay Item**  
Prep Cost

**Pay Unit**  
LSUM

TP33 GRINDING OPERATIONS PREPARATIONS

GENERAL

This item includes all work required to prepare for grinding and paving operations, as well as all work required to complete the project and return the construction area to an acceptable completed project, free of any defects or debris.

All work required to complete the sub-group listed on the bid tab, and not included in other bid items, shall be included in this item. This includes the work items listed below as well as other incidental work that may be listed within other specifications and any other work items required to complete the project.

Work shall include, but not be limited to, the following:

- The reclaiming of existing pavements by grinding, in close conformity with the lines, grades, and cross-sections shown in the contract or as designated by the Engineer.
- The saw-cutting or milling of transitions to driveway approaches, cross streets or any other surface to be transitioned from existing to new pavement.

- All gravel drives must have a sufficient taper with #53 Limestone
- Construction staking as outlined in TP10 and removal of staking upon completion of segment.
- Record drawing preparation and submittal.
- Inlet protection if structures are within the construction limits.
- Restoration of **ALL DISTURBED** pavement markings where indicated as outlined in TP30.
- Placement and removal of all traffic control associated with the grinding process and as outlined in TP9 Maintenance of Traffic.
- Removal of all construction debris generated upon completion of the segment.
- Gradation of reclaimed asphalt shall have a particle size of which 97% will pass through a 2" sieve.

**Pay Item**  
Prep Cost

**Pay Unit**  
LSUM

### TP34 – BRIDGE DECK RESURFACING

#### GENERAL

The work includes resurfacing the following bridges:

#### **NONE**

The work shall consist of providing all equipment, labor and materials to perform the following work:

1. Removing the existing asphalt wearing surface on the bridge deck without damaging the bridge beams. Milling of the asphalt will not be allowed.
2. Notifying the Engineer after the asphalt has been removed so that an inspection of the bridge deck can be performed.
3. Patching all holes or spalls in concrete bridge decks as directed by the Engineer.

4. Placing a waterproofing membrane on the bridge deck. Timber Bridges MAY OR MAY NOT require membrane, and will be noted prior to bidding.
5. **MEMBRANE SHALL NOT BE APPLIED TO BRIDGE DECKS 24 HOURS PRIOR TO PAVING**
6. Resurfacing the bridge deck to facia including approach tapers as directed with the HMA surface material specified.
7. A leveling course of asphalt may be applied to bridge deck prior to final paving, but shall not exceed 1.5”
8. Saw cutting a 1/8” thick transverse joint the width of the deck at each abutment and pier and filling the saw cut with self-leveling caulk. Saw cut must be dry and clean of debris before caulk is applied.

## MATERIALS

Waterproofing Membrane –

- a. Royston 10AN Easy Pave, Chase Corporation, distributed by Con-Quip Tristate Construction Supply, 1612 Distribution Drive, Burlington, KY 41005  
or
- b. Polyguard 665, Polyguard Products, Ennis, TX 75120

Waterproofing Membrane Adhesive – match with selected membrane supplier.

- a. Royston Roybond 713A, Chase Corporation, distributed by Con-Quip Tristate Construction Supply, 1612 Distribution Drive, Burlington, KY 41005 or
- b. Polyguard Liquid Adhesive, Polyguard Products, Ennis, TX 75120

Concrete Patch Material – 1260 MG-Krete Flex Fine, IMCO Technologies, distributed by Kuert Concrete, 18370 U.S. 20, Goshen, IN 46528

Tack – in accordance with the Standard Specifications.

HMA Surface – use the HMA material being used on the road section where the bridge is located.

Self-Leveling Caulk – Dow Corning 890-SL.

## INSTALLATION

1. Bridge Deck Surface Removal – remove all existing asphalt off of the bridge deck. Care shall be taken to not damage the bridge beams. Milling will not be allowed.
2. Bridge Deck Inspection – Notify the Engineer after the asphalt surface has been removed from the bridge deck so that an inspection can be performed to document its condition and determine the extent of surface preparation required prior to placing the waterproofing membrane and resurfacing.
3. Concrete Deck Patching – Patch all spalls in the concrete bridge deck as directed by the owner’s representative using the specified material. All work to be done in accordance with the patching material manufacturer’s recommendations.
4. Waterproofing Membrane Adhesive – Place the specified waterproofing membrane adhesive on the bridge deck. All work to be done in accordance with the adhesive manufacturer’s recommendations. The waterproofing membrane adhesive is not required on timber bridges.
5. Waterproofing Membrane – Place the specified waterproofing membrane on the bridge deck. The minimum overlap between roll segments shall be 6”. All work to be done in accordance with the membrane manufacturer’s recommendations. Tack the membrane uniformly at the application rate of 0.08 gal./sq. yd.
6. Resurface the bridge deck using the HMA surface mix specified. The thickness shall be 2” (220#/Syd) at the edges and 3.5” (385#/Syd) at the center.
7. Saw cut a 1/8” thick transverse joint the width of the deck at each abutment and pier and fill with self-leveling caulk. The saw cut shall be the full-depth of the HMA. The joint shall be on the approach side of the abutment and the center of piers.

**Pay Item**

Bridge Deck Resurfacing

**Pay Unit**

Lump Sum Each

**TP35 – DRIVEWAY TRANSITIONS****MILLED ROADS**

All Driveways shall be transitioned at their present / existing elevations and grades or less. All Concrete Driveways within the proposed reconstruction areas shall be cut and material removed. All gravel driveways must have a sufficient taper with #53 Limestone.

**GROUND ROADS**

All Driveways shall be transitioned at no greater than 10% slope (unless noted otherwise). The actual distance required into a driveway will be determined from field verification of the actual finished profile. If the distance goes beyond the existing right-of-way then contractor shall obtain property owner permission prior to proceeding. Generally all transitions will be accomplished by the placement of asphalt. Under certain circumstance where a significant grade change has occurred similar material as the existing drive maybe used i.e. limestone or as stated below for concrete drives.

All concrete driveways shall be cut and material removed. The distance to cut each

driveway may vary as described in paragraph below. Concrete shall be replaced if cut portion extends more than 24" from the newly created edge of pavement or as directed by Engineer. Replaced concrete shall be a minimum of 6" thick.

No new or existing concrete driveway shall extend into new pavement.

All gravel driveways shall have a two-foot HMA surface approach (measured from edge line of road) before completing transition to existing with, graded and compacted #53 crushed limestone.

#53 crushed limestone may be placed for temporary access if drive will not be finished during normal paving time frames.

**Limestone driveway transitions shall be placed within 48 hrs. of asphalt pavement placement.**

#### METHOD OF MEASUREMENT

Driveway transitions will be paid per ton as shoulder gravel compacted in place.

<u>Pay Item</u>	<u>Pay Unit</u>
Drive Transitions	Per Ton

#### TP36 - MAILBOX RESET

##### GENERAL

The work specified in this section includes removing existing mailboxes as shown in the contract or as designated by the Engineer, and resetting them at the locations and at the elevations designated.

The term mailbox shall include the mailbox and support on which it is mounted.

##### MATERIALS

Existing mailboxes shall be used unless damaged by Contractor.

##### CONSTRUCTION REQUIREMENTS

- a) Access to existing mailboxes shall be maintained for mail delivery service during construction.
- b) As soon as the state of the work permits and the Engineer so directs, all mailboxes shall be reset by the Contractor in permanent locations in compliance with postal regulations. The Domestic Mail Manual states that mailboxes "must be placed so that they may be safely and conveniently served by carriers without leaving their conveyances..." The Postal Service recommends that mailboxes be placed with the bottom of the box at a vertical



height of between three and one-half (3½) feet to four (4) feet from the road surface.

c) The Contractor shall replace, without additional compensation, any mailboxes, supports, or any related parts that have been damaged as a result of the construction work.

#### METHOD OF MEASUREMENT

The actual number of mailboxes reset shall be the number of each reset, complete in place as directed or designated.

The accepted number of mailboxes reset, measured as noted above, shall be paid for at the unit price for each which shall be payment in full for furnishing all material, labor, equipment, tools and incidentals necessary to complete the work.

#### Pay Item

Mailbox Reset

#### Pay Unit

Each

### TP37 – SHOULDERS

#### GENERAL

Shoulders are to be approximately 24” wide and not exceed 24”, with a slope of 2% from road edge. Shoulder material shall be placed by machine creating a uniform and smooth transition from finished asphalt surface. Shoulders shall be 53 gravel compacted in place. Shoulders may consist of millings but shall be capped with #53 gravel. Any oversized asphalt rubble, shall be removed prior to shoulder placement. Windrows adjoining gravel shoulders, left by construction, shall be leveled or disposed of prior to shoulder placement. If windrow is of minimal size and quantity, material may be incorporated with shoulder material.

#### METHOD OF MEASUREMENT

Shoulders will be paid for per ton compacted in place.

#### Pay Item

Shoulders

#### Pay Unit

Per Ton

### TP38 - HOT Poured JOINT ADHESIVE INDOT STANDARD SPECIFICATION 401.15 JOINTS

#### GENERAL

Hot poured joint adhesive in accordance with 906 shall be applied to longitudinal joints constructed between two adjacent HMA courses as outlined in Segment Specifications.

This includes joints within the traveled way as well as between any of the following if specified: traveled way and an auxiliary lane; traveled way and a paved shoulder; and auxiliary lane and a paved shoulder.

The material shall be heated in a jacketed, double boiler melting kettle. The kettle shall have an attached pressure feed wand system with applicator shoe.

The joint adhesive shall be applied to the face of the previously constructed edge at the joint using a wand applicator. Prior to application of the joint adhesive, the joint face shall be dry and free of loose material and foreign objects. The adhesive shall be applied on the joint face 1/8 in. thick at the temperature recommended by the manufacturer. Excess joint adhesive shall not be allowed to pool on the top of the previously constructed pavement course or the pavement to be overlaid. The application of the adhesive shall be made within the same day, but at least 30 minutes prior to construction of the longitudinal joint.

All longitudinal joints that have the joint adhesive applied shall be sealed using SS-1h or AE-NT asphalt.

The liquid asphalt sealant shall be a minimum width of 24 in., centered on the joint line. The sealant shall be applied at an application rate of  $0.03 \pm 0.01$  gal./sq. yd. onto a dry surface, free of any foreign or loose material, using a distributor. Areas receiving joint adhesive/sealant shall be lightly broomed to have surface debris removed. The sealant temperature at the time of application shall be at least 135°F and shall not exceed 180°F. The ambient air and pavement temperatures at the time of application shall be greater than 32°F. Temporary pavement markings be offset a sufficient distance from the longitudinal joint so as not to obstruct the installation of liquid asphalt sealant. The sealant shall be cured a minimum of five days prior to applying the permanent pavement traffic markings.

## MATERIALS

CRAFCO 34524 – Pavement Joint Adhesive or Approved Equal

## METHOD OF MEASUREMENT

Joint sealant/adhesive and asphalt sealant will be paid for combined per LFT

### Pay Item

Joint Adhesive/Sealant, Asphalt Sealant

### Pay Unit

Per LFT

TP39 – MANHOLES, INLETS, AND WATER VALVE

**GENERAL**

All work shall comply with the City of Elkhart Prevailing Standard Specifications, Divisions B:5.10 and B:5.11. Manhole, inlet, and valve box castings must be adjusted prior to the placement of pavement. Cutting of the pavement after placement to allow for adjustment of castings shall not be permitted.

**METHOD OF MEASUREMENT**

Manholes will be paid for combined per EACH

**Pay Item**

Casting, Manhole, Adjust to Grade  
Casting, Inlet, Adjust to Grade  
Casting, Water Valve, Adjust to Grade

**Pay Unit**

EACH  
EACH  
EACH

## **2025-1 CCMG FIELD DIRECTIVES**

**CC 1 COUNTY ROAD 13 (COUNTY ROAD 18 TO COUNTY ROAD 16) MILL 2" AND PAVE 2"**. BEGIN AT EAST NORTH EDGE LINE OF COUNTY ROAD 16, MILL TO WEST OF EDGELINE AT NURSERY DR ON CR 16, MILL, AND END AT NORTH EDGLINE OF COUNTY ROAD 18. INCLUDE RADIUS AND TAPERS AND BUTT JOINTS FOR A SMOOTH TRANSITION.

MILL ASPHALT IN FRONT OF CONCRETE DRIVES FOR SMOOTH TRANSITION, ASPHALT DRIVES SHALL HAVE MILLED TRANSITIONS AND WILL BE INCLUDED IN PREP COST. REMOVE EXCESS ASPHALT FROM DRIVEWAYS, MATCH DRIVEWAYS TO NEW ASPHALT. ALL MAILBOXES AND DRIVEWAYS SHALL HAVE MINIMUM 2 FOOT BUMP OUT. ADD 53 LIMESTONE FOR DRIVEWAYS IF NEEDED AND APPLY TOPSOIL FOR SHOULDERS. IF ROAD HAS DETERIORATED AND NEEDS TO BE MILLED MORE THAN 2 INCHES, A FIELD DIRECTIVE/CHANGE ORDER MAY BE NEEDED FOR EXTRA MILLING.

BEFORE ADJOINING PAVEMENT IS PLACED, LONGITUDINAL JOINT SHALL HAVE JOINT SEAL/ADHESIVE APPLIED. ALL MAILBOXES AND DRIVEWAYS SHALL HAVE MINIMUM 2 FOOT BUMP OUT. ALL LOOSE DEBRIS AT DRIVEWAYS SHALL BE REMOVED. ALL DEBRIS GENERATED THROUGH THE CONSTRUCTION PROCESS, SHALL BE REMOVED AT COMPLETION OF PAVING. +/- 2 FOOT TOPSOIL SHOULDERS SHALL BE ADDED AS WELL AS LIMESTONE FOR GRAVEL DRIVEWAY TAPERS. LIMESTONE FOR DRIVEWAY TAPERS WILL BE PAID FOR AS SHOULDER GRAVEL. ASPHALT DRIVES SHALL HAVE MILL JOINT FOR TRANSITION. MILLED TRANSITIONS OF ASPHALT DRIVES SHALL BE INCLUDED IN PREP COST. REMOVAL OF CONCRETE DRIVES WILL BE PAID BY PREP COST. ALL TRAFFIC CONTROL, MOBILIZATION/DEMobilIZATION, AND ANY INCIDENTALS NOT SPECIFIED AS LINE ITEMS, SHALL BE INCLUDED IN PREP COST. (0.53 MILES)

**CC 2 COUNTY ROAD 46 (STATE ROAD 19 TO COUNTY ROAD 11) MILL 2" AND PAVE 2"**. BEGIN AT EAST EDGE LINE OF STATE ROAD 19 AND END AT WEST EDGE LINE OF COUNTY ROAD 11. INCLUDING 20 FEET NORTH AND SOUTH ON CR 9 AND CR 7. INCLUDE RADIUS AND TAPERS AND BUTT JOINTS FOR A SMOOTH TRANSITION.

MILL ASPHALT MILL ASPHALT IN FRONT OF CONCRETE DRIVES FOR SMOOTH TRANSITION, ASPHALT DRIVES SHALL HAVE MILLED TRANSITIONS AND WILL BE INCLUDED IN PREP COST. REMOVE EXCESS ASPHALT FROM DRIVEWAYS, MATCH DRIVEWAYS TO NEW ASPHALT. ALL MAILBOXES AND DRIVEWAYS SHALL HAVE MINIMUM 2 FOOT BUMP OUT. ADD 53 LIMESTONE FOR DRIVEWAYS IF NEEDED AND APPLY TOPSOIL FOR SHOULDERS. IF ROAD HAS DETERIORATED AND NEEDS TO BE MILLED MORE THAN 2 INCHES, A FIELD DIRECTIVE/CHANGE ORDER MAY BE NEEDED FOR EXTRA MILLING.

BEFORE ADJOINING PAVEMENT IS PLACED, LONGITUDINAL JOINT SHALL HAVE JOINT SEAL/ADHESIVE APPLIED. ALL MAILBOXES AND DRIVEWAYS SHALL HAVE MINIMUM 2 FOOT BUMP OUT. ALL LOOSE DEBRIS AT DRIVEWAYS SHALL BE REMOVED. ALL DEBRIS GENERATED THROUGH THE CONSTRUCTION PROCESS, SHALL BE REMOVED AT COMPLETION OF PAVING. +/- 2 FOOT TOPSOIL SHOULDERS SHALL BE ADDED AS WELL AS LIMESTONE FOR GRAVEL DRIVEWAY TAPERS. LIMESTONE FOR DRIVEWAY TAPERS WILL BE PAID FOR AS SHOULDER GRAVEL. ASPHALT DRIVES SHALL HAVE MILL JOINT FOR TRANSITION. MILLED TRANSITIONS OF ASPHALT DRIVES SHALL BE INCLUDED IN PREP COST. REMOVAL OF CONCRETE DRIVES WILL BE PAID BY PREP COST. ALL TRAFFIC CONTROL, MOBILIZATION/DEMobilIZATION, AND ANY INCIDENTALS NOT SPECIFIED AS LINE ITEMS, SHALL BE INCLUDED IN PREP COST. (3.00 MILES)

**CC 3 COUNTY ROAD 28 (COUNTY ROAD 13 – COUNTY ROAD 11) GRIND FULL DEPTH AND PAVE 2.5”** BEGIN AT EAST EDGE LINE OF COUNTY ROAD 11 AND END AT WEST EDGE LINE OF COUNTY ROAD 13. INCLUDE TAPERS AND BUTT JOINTS FOR A SMOOTH TRANSITION.

CONCRETE DRIVEWAYS SHALL BE CUT AND REMOVED NO LESS THAN 3 FEET BUT NO GREATER THAN 5 FEET, OR AS DIRECTED BY OWNER, IF UNABLE TO MATCH DRIVEWAY TO ROAD. DRIVEWAY CUT AND REMOVAL WILL BE PAID BY SYS. CONCRETE DRIVES WILL NEED TO BE EVALUATED. ASPHALT DRIVES SHALL HAVE MILL JOINT FOR TRANSITION. MILLED TRANSITIONS OF ASPHALT DRIVES SHALL BE INCLUDED IN PREP COST.

BEFORE ADJOINING PAVEMENT IS PLACED, LONGITUDINAL SURFACE JOINT SHALL HAVE JOINT SEAL/ADHESIVE APPLIED. ALL MAILBOXES AND DRIVEWAYS SHALL HAVE MINIMUM 2 FOOT BUMP OUT. PAVEMENT IS TO HAVE ALL DISTURBED PAVEMENT MARKINGS REAPPLIED TO PRE-CONSTRUCTION LOCATIONS, AS OUTLINED IN THE INDIANA MUTCD. ALL DEBRIS GENERATED THROUGH THE CONSTRUCTION PROCESS, SHALL BE REMOVED AT COMPLETION OF PAVING. TEMPORARY PAVEMENT MARKINGS SHALL BE APPLIED SAME DAY AS COMPLETED PAVING, WITH PERMANENT PAVEMENT MARKINGS BEING APPLIED NO LATER THAN 14 DAYS AFTER PAVEMENT PLACEMENT. 2 FOOT GRAVEL SHOULDERS SHALL BE ADDED AS WELL AS LIMESTONE FOR GRAVEL DRIVEWAY TAPERS. LIMESTONE FOR DRIVEWAY TAPERS WILL BE PAID FOR AS SHOULDER GRAVEL. ALL GRINDING, TRAFFIC CONTROL, MOBILIZATION/DEMobilIZATION, AND ANY INCIDENTALS SHALL BE INCLUDED IN PREP COST. ALL MEASUREMENTS FOR TAPERS, CROSS STREETS AND INTERSECTIONS WILL BE FIELD VERIFIED BY ENGINEER. (1.00 MILES)

**CC 4 COUNTY ROAD 7 (COUNTY ROAD 52 – COUNTY ROAD 46) MILL 2” AND PAVE 2”.** BEGIN AT NORTH EDGE LINE OF COUNTY ROAD 52, MILL UP TO STOP SIGN ON CR 150, MILL UTP TO STOP SIGN ON EAST AND WEST ON CR 50, AND END AT SOUTH EDGE LINE OF COUNTY ROAD 46 INCLUDE TAPERS AND BUTT JOINTS FOR A SMOOTH TRANSITION.

MILL ASPHALT IN FRONT OF CONCRETE DRIVES FOR SMOOTH TRANSITION, ASPHALT DRIVES SHALL HAVE MILLED TRANSITIONS AND WILL BE INCLUDED IN PREP COST. REMOVE EXCESS ASPHALT FROM DRIVEWAYS, MATCH DRIVEWAYS TO NEW ASPHALT. ALL MAILBOXES AND DRIVEWAYS SHALL HAVE MINIMUM 2 FOOT BUMP OUT. ADD 53 LIMESTONE FOR DRIVEWAYS IF NEEDED AND APPLY TOPSOIL FOR SHOULDERS. IF ROAD HAS DETERIORATED AND NEEDS TO BE MILLED MORE THAN 2 INCHES, A FIELD DIRECTIVE/CHANGE ORDER MAY BE NEEDED FOR EXTRA MILLING.

BEFORE ADJOINING PAVEMENT IS PLACED, LONGITUDINAL JOINT SHALL HAVE JOINT SEAL/ADHESIVE APPLIED. ALL MAILBOXES AND DRIVEWAYS SHALL HAVE MINIMUM 2 FOOT BUMP OUT. ALL LOOSE DEBRIS AT DRIVEWAYS SHALL BE REMOVED. ALL DEBRIS GENERATED THROUGH THE CONSTRUCTION PROCESS, SHALL BE REMOVED AT COMPLETION OF PAVING. +/- 2 FOOT TOPSOIL SHOULDERS SHALL BE ADDED AS WELL AS LIMESTONE FOR GRAVEL DRIVEWAY TAPERS. LIMESTONE FOR DRIVEWAY TAPERS WILL BE PAID FOR AS SHOULDER GRAVEL. ASPHALT DRIVES SHALL HAVE MILL JOINT FOR TRANSITION. MILLED TRANSITIONS OF ASPHALT DRIVES SHALL BE INCLUDED IN PREP COST. REMOVAL OF CONCRETE DRIVES WILL BE PAID BY PREP COST. ALL TRAFFIC CONTROL, MOBILIZATION/DEMobilIZATION, AND ANY INCIDENTALS NOT SPECIFIED AS LINE ITEMS, SHALL BE INCLUDED IN PREP COST. (2.50 MILES)

**CC 5 COUNTY ROAD 111 (COUNTY ROAD 20 – SHAFFER AVE) MILL 2” AND PAVE 2”**. BEGIN AT NORTH EDGE LINE OF COUNTY ROAD 20 AND END AT NORTH EDGE LINE OF SHAFFER AVE INCLUDE TAPERS AND BUTT JOINTS FOR A SMOOTH TRANSITION.

MILL ASPHALT IN FRONT OF CONCRETE DRIVES FOR SMOOTH TRANSITION, ASPHALT DRIVES SHALL HAVE MILLED TRANSITIONS AND WILL BE INCLUDED IN PREP COST. REMOVE EXCESS ASPHALT FROM DRIVEWAYS, MATCH DRIVEWAYS TO NEW ASPHALT. ALL MAILBOXES AND DRIVEWAYS SHALL HAVE MINIMUM 2 FOOT BUMP OUT. ADD 53 LIMESTONE FOR DRIVEWAYS IF NEEDED AND APPLY TOPSOIL FOR SHOULDERS. IF ROAD HAS DETERIORATED AND NEEDS TO BE MILLED MORE THAN 2 INCHES, A FIELD DIRECTIVE/CHANGE ORDER MAY BE NEEDED FOR EXTRA MILLING.

BEFORE ADJOINING PAVEMENT IS PLACED, LONGITUDINAL JOINT SHALL HAVE JOINT SEAL/ADHESIVE APPLIED. ALL MAILBOXES AND DRIVEWAYS SHALL HAVE MINIMUM 2 FOOT BUMP OUT. ALL LOOSE DEBRIS AT DRIVEWAYS SHALL BE REMOVED. ALL DEBRIS GENERATED THROUGH THE CONSTRUCTION PROCESS, SHALL BE REMOVED AT COMPLETION OF PAVING. +/- 2 FOOT TOPSOIL SHOULDERS SHALL BE ADDED AS WELL AS LIMESTONE FOR GRAVEL DRIVEWAY TAPERS. LIMESTONE FOR DRIVEWAY TAPERS WILL BE PAID FOR AS SHOULDER GRAVEL. ASPHALT DRIVES SHALL HAVE MILL JOINT FOR TRANSITION. MILLED TRANSITIONS OF ASPHALT DRIVES SHALL BE INCLUDED IN PREP COST. REMOVAL OF CONCRETE DRIVES WILL BE PAID BY PREP COST. ALL TRAFFIC CONTROL, MOBILIZATION/DEMobilIZATION, AND ANY INCIDENTALS NOT SPECIFIED AS LINE ITEMS, SHALL BE INCLUDED IN PREP COST. (0.41 MILES)

**CC 6 COUNTY ROAD 7 (COUNTY ROAD 38 – COUNTY ROAD 36) GRIND FULL DEPTH AND PAVE 2.5”** BEGIN ON SOUTH EDGELINE OF COUNTY ROAD 36 AND END AT NORTH EDGELINE OF COUNTY ROAD 38. INCLUDE TAPERS AND BUTT JOINTS FOR A SMOOTH TRANSITION.

CONCRETE DRIVEWAYS SHALL BE CUT AND REMOVED NO LESS THAN 3 FEET BUT NO GREATER THAN 5 FEET, OR AS DIRECTED BY OWNER, IF UNABLE TO MATCH DRIVEWAY TO ROAD. DRIVEWAY CUT AND REMOVAL WILL BE PAID BY SYS. CONCRETE DRIVES WILL NEED TO BE EVALUATED. ASPHALT DRIVES SHALL HAVE MILL JOINT FOR TRANSITION. MILLED TRANSITIONS OF ASPHALT DRIVES SHALL BE INCLUDED IN PREP COST.

BEFORE ADJOINING PAVEMENT IS PLACED, LONGITUDINAL SURFACE JOINT SHALL HAVE JOINT SEAL/ADHESIVE APPLIED. ALL MAILBOXES AND DRIVEWAYS SHALL HAVE MINIMUM 2 FOOT BUMP OUT. PAVEMENT IS TO HAVE ALL DISTURBED PAVEMENT MARKINGS REAPPLIED TO PRE-CONSTRUCTION LOCATIONS, AS OUTLINED IN THE INDIANA MUTCD. ALL DEBRIS GENERATED THROUGH THE CONSTRUCTION PROCESS, SHALL BE REMOVED AT COMPLETION OF PAVING. TEMPORARY PAVEMENT MARKINGS SHALL BE APPLIED SAME DAY AS COMPLETED PAVING, WITH PERMANENT PAVEMENT MARKINGS BEING APPLIED NO LATER THAN 14 DAYS AFTER PAVEMENT PLACEMENT. 2 FOOT GRAVEL SHOULDERS SHALL BE ADDED AS WELL AS LIMESTONE FOR GRAVEL DRIVEWAY TAPERS. LIMESTONE FOR DRIVEWAY TAPERS WILL BE PAID FOR AS SHOULDER GRAVEL. ALL GRINDING, TRAFFIC CONTROL, MOBILIZATION/DEMobilIZATION, AND ANY INCIDENTALS SHALL BE INCLUDED IN PREP COST. ALL

MEASUREMENTS FOR TAPERS, CROSS STREETS AND INTERSECTIONS WILL BE FIELD VERIFIED BY ENGINEER. (1.00 MILES)

**CC 7 COUNTY ROAD 24 (STATE ROAD 15 – COUNTY ROAD 27) GRIND FULL DEPTH AND PAVE 2.5”** BEGIN ON EAST EDGELINE OF STATE ROAD 15 AND END AT WEST EDGELINE OF COUNTY ROAD 27. INCLUDE RADIUS AND TAPERS AND BUTT JOINTS FOR A SMOOTH TRANSITION.

CONCRETE DRIVEWAYS SHALL BE CUT AND REMOVED NO LESS THAN 3 FEET BUT NO GREATER THAN 5 FEET, OR AS DIRECTED BY OWNER, IF UNABLE TO MATCH DRIVEWAY TO ROAD. DRIVEWAY CUT AND REMOVAL WILL BE PAID BY SYS. CONCRETE DRIVES WILL NEED TO BE EVALUATED. ASPHALT DRIVES SHALL HAVE MILL JOINT FOR TRANSITION. MILLED TRANSITIONS OF ASPHALT DRIVES SHALL BE INCLUDED IN PREP COST.

BEFORE ADJOINING PAVEMENT IS PLACED, LONGITUDINAL SURFACE JOINT SHALL HAVE JOINT SEAL/ADHESIVE APPLIED. ALL MAILBOXES AND DRIVEWAYS SHALL HAVE MINIMUM 2 FOOT BUMP OUT. PAVEMENT IS TO HAVE ALL DISTURBED PAVEMENT MARKINGS REAPPLIED TO PRE-CONSTRUCTION LOCATIONS, AS OUTLINED IN THE INDIANA MUTCD. ALL DEBRIS GENERATED THROUGH THE CONSTRUCTION PROCESS, SHALL BE REMOVED AT COMPLETION OF PAVING. TEMPORARY PAVEMENT MARKINGS SHALL BE APPLIED SAME DAY AS COMPLETED PAVING, WITH PERMANENT PAVEMENT MARKINGS BEING APPLIED NO LATER THAN 14 DAYS AFTER PAVEMENT PLACEMENT. 2 FOOT GRAVEL SHOULDERS SHALL BE ADDED AS WELL AS LIMESTONE FOR GRAVEL DRIVEWAY TAPERS. LIMESTONE FOR DRIVEWAY TAPERS WILL BE PAID FOR AS SHOULDER GRAVEL. ALL GRINDING, TRAFFIC CONTROL, MOBILIZATION/DEMobilIZATION, AND ANY INCIDENTALS SHALL BE INCLUDED IN PREP COST. ALL MEASUREMENTS FOR TAPERS, CROSS STREETS AND INTERSECTIONS WILL BE FIELD VERIFIED BY ENGINEER. (1.24 MILES)

**CC 8 COUNTY ROAD 11 (COUNTY ROAD 48 – COUNTY ROAD 46) GRIND FULL DEPTH AND PAVE 2.5”** BEGIN ON NORTH EDGELINE OF COUNTY ROAD 48 AND END SOUTH EDGELINE OF COUNTY ROAD 46. INCLUDE RADIUS AND TAPERS AND BUTT JOINTS FOR A SMOOTH TRANSITION.

CONCRETE DRIVEWAYS SHALL BE CUT AND REMOVED NO LESS THAN 3 FEET BUT NO GREATER THAN 5 FEET, OR AS DIRECTED BY OWNER, IF UNABLE TO MATCH DRIVEWAY TO ROAD. DRIVEWAY CUT AND REMOVAL WILL BE PAID BY SYS. CONCRETE DRIVES WILL NEED TO BE EVALUATED. ASPHALT DRIVES SHALL HAVE MILL JOINT FOR TRANSITION. MILLED TRANSITIONS OF ASPHALT DRIVES SHALL BE INCLUDED IN PREP COST.

BEFORE ADJOINING PAVEMENT IS PLACED, LONGITUDINAL SURFACE JOINT SHALL HAVE JOINT SEAL/ADHESIVE APPLIED. ALL MAILBOXES AND DRIVEWAYS SHALL HAVE MINIMUM 2 FOOT BUMP OUT. PAVEMENT IS TO HAVE ALL DISTURBED PAVEMENT MARKINGS REAPPLIED TO PRE-CONSTRUCTION LOCATIONS, AS OUTLINED IN THE INDIANA MUTCD. ALL DEBRIS GENERATED THROUGH THE CONSTRUCTION PROCESS, SHALL BE REMOVED AT COMPLETION OF PAVING. TEMPORARY PAVEMENT MARKINGS SHALL BE APPLIED SAME DAY AS COMPLETED PAVING, WITH PERMANENT PAVEMENT MARKINGS BEING APPLIED NO LATER THAN 14 DAYS AFTER PAVEMENT PLACEMENT. 2 FOOT GRAVEL SHOULDERS SHALL BE ADDED AS WELL AS LIMESTONE FOR GRAVEL DRIVEWAY TAPERS. LIMESTONE FOR

DRIVEWAY TAPERS WILL BE PAID FOR AS SHOULDER GRAVEL. ALL GRINDING, TRAFFIC CONTROL, MOBILIZATION/DEMobilIZATION, AND ANY INCIDENTALS SHALL BE INCLUDED IN PREP COST. ALL MEASUREMENTS FOR TAPERS, CROSS STREETS AND INTERSECTIONS WILL BE FIELD VERIFIED BY ENGINEER. (1.00 MILES)

**CC 9 COUNTY ROAD 46 (STATE ROAD 19 – COUNTY ROAD 1) GRIND FULL DEPTH AND PAVE 2.5”** BEGIN ON WEST EDGE LINE OF STATE ROAD 19 AND END AT EAST EDGELINE OF COUNTY ROAD 1. INCLUDE RADIUS AND TAPERS AND BUTT JOINTS FOR A SMOOTH TRANSITION.

CONCRETE DRIVEWAYS SHALL BE CUT AND REMOVED NO LESS THAN 3 FEET BUT NO GREATER THAN 5 FEET, OR AS DIRECTED BY OWNER, IF UNABLE TO MATCH DRIVEWAY TO ROAD. DRIVEWAY CUT AND REMOVAL WILL BE PAID BY SYS. CONCRETE DRIVES WILL NEED TO BE EVALUATED. ASPHALT DRIVES SHALL HAVE MILL JOINT FOR TRANSITION. MILLED TRANSITIONS OF ASPHALT DRIVES SHALL BE INCLUDED IN PREP COST.

BEFORE ADJOINING PAVEMENT IS PLACED, LONGITUDINAL SURFACE JOINT SHALL HAVE JOINT SEAL/ADHESIVE APPLIED. ALL MAILBOXES AND DRIVEWAYS SHALL HAVE MINIMUM 2 FOOT BUMP OUT. PAVEMENT IS TO HAVE ALL DISTURBED PAVEMENT MARKINGS REAPPLIED TO PRE-CONSTRUCTION LOCATIONS, AS OUTLINED IN THE INDIANA MUTCD. ALL DEBRIS GENERATED THROUGH THE CONSTRUCTION PROCESS, SHALL BE REMOVED AT COMPLETION OF PAVING. TEMPORARY PAVEMENT MARKINGS SHALL BE APPLIED SAME DAY AS COMPLETED PAVING, WITH PERMANENT PAVEMENT MARKINGS BEING APPLIED NO LATER THAN 14 DAYS AFTER PAVEMENT PLACEMENT. 2 FOOT GRAVEL SHOULDERS SHALL BE ADDED AS WELL AS LIMESTONE FOR GRAVEL DRIVEWAY TAPERS. LIMESTONE FOR DRIVEWAY TAPERS WILL BE PAID FOR AS SHOULDER GRAVEL. ALL GRINDING, TRAFFIC CONTROL, MOBILIZATION/DEMobilIZATION, AND ANY INCIDENTALS SHALL BE INCLUDED IN PREP COST. ALL MEASUREMENTS FOR TAPERS, CROSS STREETS AND INTERSECTIONS WILL BE FIELD VERIFIED BY ENGINEER. (2.00 MILES)

**CC 10 COUNTY ROAD 11 (COUNTY ROAD 11N – COUNTY ROAD 11S) MILL 2” AND PAVE 2”.** **ALSO NAMED AS CR 22 (CR11N – CR11S)** BEGIN ON WEST EDGELINE OF COUNTY ROAD 11N AND END AT WEST EDGELINE OF COUNTY ROAD 11S. INCLUDE RADIUS AND TAPERS AND BUTT JOINTS FOR A SMOOTH TRANSITION.

MILL ASPHALT IN FRONT OF CONCRETE DRIVES FOR SMOOTH TRANSITION, ASPHALT DRIVES SHALL HAVE MILLED TRANSITIONS AND WILL BE INCLUDED IN PREP COST. REMOVE EXCESS ASPHALT FROM DRIVEWAYS, MATCH DRIVEWAYS TO NEW ASPHALT. ALL MAILBOXES AND DRIVEWAYS SHALL HAVE MINIMUM 2 FOOT BUMP OUT. ADD 53 LIMESTONE FOR DRIVEWAYS IF NEEDED AND APPLY TOPSOIL FOR SHOULDERS. IF ROAD HAS DETERIORATED AND NEEDS TO BE MILLED MORE THAN 2 INCHES, A FIELD DIRECTIVE/CHANGE ORDER MAY BE NEEDED FOR EXTRA MILLING.

BEFORE ADJOINING PAVEMENT IS PLACED, LONGITUDINAL JOINT SHALL HAVE JOINT SEAL/ADHESIVE APPLIED. ALL MAILBOXES AND DRIVEWAYS SHALL HAVE MINIMUM 2 FOOT BUMP OUT. ALL LOOSE DEBRIS AT DRIVEWAYS SHALL BE REMOVED. ALL DEBRIS GENERATED THROUGH THE CONSTRUCTION PROCESS, SHALL BE REMOVED AT COMPLETION OF PAVING. +/- 2 FOOT TOPSOIL SHOULDERS SHALL BE ADDED AS WELL AS LIMESTONE FOR GRAVEL DRIVEWAY TAPERS. LIMESTONE FOR DRIVEWAY TAPERS WILL BE PAID FOR AS SHOULDER GRAVEL. ASPHALT DRIVES SHALL HAVE MILL JOINT FOR TRANSITION.



MILLED TRANSITIONS OF ASPHALT DRIVES SHALL BE INCLUDED IN PREP COST. REMOVAL OF CONCRETE DRIVES WILL BE PAID BY PREP COST. ALL TRAFFIC CONTROL, MOBILIZATION/DEMobilIZATION, AND ANY INCIDENTALS NOT SPECIFIED AS LINE ITEMS, SHALL BE INCLUDED IN PREP COST. (0.48 MILES)

**CC 11 COUNTY ROAD 48 (COUNTY ROAD 11 – COUNTY ROAD 13) GRIND FULL DEPTH AND PAVE 2.5”** BEGIN ON EAST EDGELINE OF COUNTY ROAD 11 AND END AT WEST EDGELINE OF COUNTY ROAD 13. INCLUDE RADIUS AND TAPERS AND BUTT JOINTS FOR A SMOOTH TRANSITION.

CONCRETE DRIVEWAYS SHALL BE CUT AND REMOVED NO LESS THAN 3 FEET BUT NO GREATER THAN 5 FEET, OR AS DIRECTED BY OWNER, IF UNABLE TO MATCH DRIVEWAY TO ROAD. DRIVEWAY CUT AND REMOVAL WILL BE PAID BY SYS. CONCRETE DRIVES WILL NEED TO BE EVALUATED. ASPHALT DRIVES SHALL HAVE MILL JOINT FOR TRANSITION. MILLED TRANSITIONS OF ASPHALT DRIVES SHALL BE INCLUDED IN PREP COST.

BEFORE ADJOINING PAVEMENT IS PLACED, LONGITUDINAL SURFACE JOINT SHALL HAVE JOINT SEAL/ADHESIVE APPLIED. ALL MAILBOXES AND DRIVEWAYS SHALL HAVE MINIMUM 2 FOOT BUMP OUT. PAVEMENT IS TO HAVE ALL DISTURBED PAVEMENT MARKINGS REAPPLIED TO PRE-CONSTRUCTION LOCATIONS, AS OUTLINED IN THE INDIANA MUTCD. ALL DEBRIS GENERATED THROUGH THE CONSTRUCTION PROCESS, SHALL BE REMOVED AT COMPLETION OF PAVING. TEMPORARY PAVEMENT MARKINGS SHALL BE APPLIED SAME DAY AS COMPLETED PAVING, WITH PERMANENT PAVEMENT MARKINGS BEING APPLIED NO LATER THAN 14 DAYS AFTER PAVEMENT PLACEMENT. 2 FOOT GRAVEL SHOULDERS SHALL BE ADDED AS WELL AS LIMESTONE FOR GRAVEL DRIVEWAY TAPERS. LIMESTONE FOR DRIVEWAY TAPERS WILL BE PAID FOR AS SHOULDER GRAVEL. ALL GRINDING, TRAFFIC CONTROL, MOBILIZATION/DEMobilIZATION, AND ANY INCIDENTALS SHALL BE INCLUDED IN PREP COST. ALL MEASUREMENTS FOR TAPERS, CROSS STREETS AND INTERSECTIONS WILL BE FIELD VERIFIED BY ENGINEER. (1.00 MILES)

**CC 12 COUNTY ROAD 146 (COUNTY ROAD 29 – COUNTY ROAD 31) GRIND FULL DEPTH AND PAVE 2.5”** BEGIN ON EAST EDGELINE OF COUNTY ROAD 29 AND END AT WEST EDGELINE OF COUNTY ROAD 31. INCLUDE RADIUS AND TAPERS AND BUTT JOINTS FOR A SMOOTH TRANSITION.

CONCRETE DRIVEWAYS SHALL BE CUT AND REMOVED NO LESS THAN 3 FEET BUT NO GREATER THAN 5 FEET, OR AS DIRECTED BY OWNER, IF UNABLE TO MATCH DRIVEWAY TO ROAD. DRIVEWAY CUT AND REMOVAL WILL BE PAID BY SYS. CONCRETE DRIVES WILL NEED TO BE EVALUATED. ASPHALT DRIVES SHALL HAVE MILL JOINT FOR TRANSITION. MILLED TRANSITIONS OF ASPHALT DRIVES SHALL BE INCLUDED IN PREP COST.

BEFORE ADJOINING PAVEMENT IS PLACED, LONGITUDINAL SURFACE JOINT SHALL HAVE JOINT SEAL/ADHESIVE APPLIED. ALL MAILBOXES AND DRIVEWAYS SHALL HAVE MINIMUM 2 FOOT BUMP OUT. PAVEMENT IS TO HAVE ALL DISTURBED PAVEMENT MARKINGS REAPPLIED TO PRE-CONSTRUCTION LOCATIONS, AS OUTLINED IN THE INDIANA MUTCD. ALL DEBRIS GENERATED THROUGH THE CONSTRUCTION PROCESS, SHALL BE REMOVED AT COMPLETION OF PAVING. TEMPORARY PAVEMENT MARKINGS SHALL BE APPLIED SAME DAY AS COMPLETED PAVING, WITH PERMANENT PAVEMENT

MARKINGS BEING APPLIED NO LATER THAN 14 DAYS AFTER PAVEMENT PLACEMENT. 2 FOOT GRAVEL SHOULDERS SHALL BE ADDED AS WELL AS LIMESTONE FOR GRAVEL DRIVEWAY TAPERS. LIMESTONE FOR DRIVEWAY TAPERS WILL BE PAID FOR AS SHOULDER GRAVEL. ALL GRINDING, TRAFFIC CONTROL, MOBILIZATION/DEMobilIZATION, AND ANY INCIDENTALS SHALL BE INCLUDED IN PREP COST. ALL MEASUREMENTS FOR TAPERS, CROSS STREETS AND INTERSECTIONS WILL BE FIELD VERIFIED BY ENGINEER. (1.00 MILES)

**CC 13 COUNTY ROAD 50 (COUNTY ROAD 29 – COUNTY ROAD 31) GRIND FULL DEPTH AND PAVE 2.5”** BEGIN ON EAST EDGELINE OF COUNTY ROAD 29 AND END AT WEST EDGELINE OF COUNTY ROAD 31. INCLUDE RADIUS AND TAPERS WITH BUTT JOINTS FOR SMOOTH TRANSITION.

CONCRETE DRIVEWAYS SHALL BE CUT AND REMOVED NO LESS THAN 3 FEET BUT NO GREATER THAN 5 FEET, OR AS DIRECTED BY OWNER, IF UNABLE TO MATCH DRIVEWAY TO ROAD. DRIVEWAY CUT AND REMOVAL WILL BE PAID BY SYS. CONCRETE DRIVES WILL NEED TO BE EVALUATED. ASPHALT DRIVES SHALL HAVE MILL JOINT FOR TRANSITION. MILLED TRANSITIONS OF ASPHALT DRIVES SHALL BE INCLUDED IN PREP COST.

BEFORE ADJOINING PAVEMENT IS PLACED, LONGITUDINAL SURFACE JOINT SHALL HAVE JOINT SEAL/ADHESIVE APPLIED. ALL MAILBOXES AND DRIVEWAYS SHALL HAVE MINIMUM 2 FOOT BUMP OUT. PAVEMENT IS TO HAVE ALL DISTURBED PAVEMENT MARKINGS REAPPLIED TO PRE-CONSTRUCTION LOCATIONS, AS OUTLINED IN THE INDIANA MUTCD. ALL DEBRIS GENERATED THROUGH THE CONSTRUCTION PROCESS, SHALL BE REMOVED AT COMPLETION OF PAVING. TEMPORARY PAVEMENT MARKINGS SHALL BE APPLIED SAME DAY AS COMPLETED PAVING, WITH PERMANENT PAVEMENT MARKINGS BEING APPLIED NO LATER THAN 14 DAYS AFTER PAVEMENT PLACEMENT. 2 FOOT GRAVEL SHOULDERS SHALL BE ADDED AS WELL AS LIMESTONE FOR GRAVEL DRIVEWAY TAPERS. LIMESTONE FOR DRIVEWAY TAPERS WILL BE PAID FOR AS SHOULDER GRAVEL. ALL GRINDING, TRAFFIC CONTROL, MOBILIZATION/DEMobilIZATION, AND ANY INCIDENTALS SHALL BE INCLUDED IN PREP COST. ALL MEASUREMENTS FOR TAPERS, CROSS STREETS AND INTERSECTIONS WILL BE FIELD VERIFIED BY ENGINEER. (0.61 MILES)

**CC 14A FORREST LAKES DR (STATE ROAD 120 - END) MILL 2” AND PAVE 2”** BEGIN ON SOUTH EDGELINE OF STATE ROAD 120 AND END AT END OF FORREST LAKES DR CUL-DE-SAC. INCLUDE RADIUS AND TAPERS WITH BUTT JOINTS FOR SMOOTH TRANSITION.

MILL ASPHALT IN FRONT OF CONCRETE DRIVES FOR SMOOTH TRANSITION, ASPHALT DRIVES SHALL HAVE MILLED TRANSITIONS AND WILL BE INCLUDED IN PREP COST. REMOVE EXCESS ASPHALT FROM DRIVEWAYS, MATCH DRIVEWAYS TO NEW ASPHALT. ALL MAILBOXES AND DRIVEWAYS SHALL HAVE MINIMUM 2 FOOT BUMP OUT. ADD 53 LIMESTONE FOR DRIVEWAYS IF NEEDED AND APPLY GRAVEL FOR SHOULDERS. IF ROAD HAS DETERIORATED AND NEEDS TO BE MILLED MORE THAN 2 INCHES, A FIELD DIRECTIVE/CHANGE ORDER MAY BE NEEDED FOR EXTRA MILLING.

BEFORE ADJOINING PAVEMENT IS PLACED, LONGITUDINAL JOINT SHALL HAVE JOINT SEAL/ADHESIVE APPLIED. ALL MAILBOXES AND DRIVEWAYS SHALL HAVE MINIMUM 2 FOOT BUMP OUT. ALL LOOSE DEBRIS AT DRIVEWAYS SHALL BE REMOVED. ALL DEBRIS GENERATED THROUGH THE CONSTRUCTION PROCESS, SHALL BE REMOVED AT COMPLETION OF PAVING. +/- 2 FOOT GRAVEL SHOULDERS SHALL BE

ADDED AS WELL AS LIMESTONE FOR GRAVEL DRIVEWAY TAPERS. PERMANENT PAVEMENT MARKING MUST BEING APPLIED NO LATER THAN 14 DAYS AFTER PAVEMENT PLACEMENT. LIMESTONE FOR DRIVEWAY TAPERS WILL BE PAID FOR AS SHOULDER GRAVEL. ASPHALT DRIVES SHALL HAVE MILL JOINT FOR TRANSITION. MILLED TRANSITIONS OF ASPHALT DRIVES SHALL BE INCLUDED IN PREP COST. REMOVAL OF CONCRETE DRIVES WILL BE PAID BY PREP COST. ALL TRAFFIC CONTROL, MOBILIZATION/DEMobilIZATION, AND ANY INCIDENTALS NOT SPECIFIED AS LINE ITEMS, SHALL BE INCLUDED IN PREP COST. (0.87 MILES)

**CC 14B POPLAR LN (END - END) MILL 2" AND PAVE 2"** BEGIN ON POPLAR LN CUL-DA-SAC AND END AT EAST POPLAR LN CUL-DE-SAC. INCLUDING RADIUS AND TAPER FOR SMOOTH TRANSITION. REMOVE ALL ORGANICS IN CUL-DE-SAC WHICH INCLUDES TREES AND TOPSIL. EXCAVATE 6 INCHES BELOW PAVEMENT, PLACE NO 53 AGGREGATE, THE REST SHALL BE HOT MIX ASPHALT. ALL ORGANICS REMOVED SHALL BE INCLUDED IN PREP COST.

MILL ASPHALT IN FRONT OF CONCRETE DRIVES FOR SMOOTH TRANSITION, ASPHALT DRIVES SHALL HAVE MILLED TRANSITIONS AND WILL BE INCLUDED IN PREP COST. REMOVE EXCESS ASPHALT FROM DRIVEWAYS, MATCH DRIVEWAYS TO NEW ASPHALT. ALL MAILBOXES AND DRIVEWAYS SHALL HAVE MINIMUM 2 FOOT BUMP OUT. ADD 53 LIMESTONE FOR DRIVEWAYS IF NEEDED AND APPLY GRAVEL FOR SHOULDERS. IF ROAD HAS DETERIORATED AND NEEDS TO BE MILLED MORE THAN 2 INCHES, A FIELD DIRECTIVE/CHANGE ORDER MAY BE NEEDED FOR EXTRA MILLING.

BEFORE ADJOINING PAVEMENT IS PLACED, LONGITUDINAL JOINT SHALL HAVE JOINT SEAL/ADHESIVE APPLIED. ALL MAILBOXES AND DRIVEWAYS SHALL HAVE MINIMUM 2 FOOT BUMP OUT. ALL LOOSE DEBRIS AT DRIVEWAYS SHALL BE REMOVED. ALL DEBRIS GENERATED THROUGH THE CONSTRUCTION PROCESS, SHALL BE REMOVED AT COMPLETION OF PAVING. +/- 2 FOOT GRAVEL SHOULDERS SHALL BE ADDED AS WELL AS LIMESTONE FOR GRAVEL DRIVEWAY TAPERS. PERMANENT PAVEMENT MARKING MUST BEING APPLIED NO LATER THAN 14 DAYS AFTER PAVEMENT PLACEMENT. LIMESTONE FOR DRIVEWAY TAPERS WILL BE PAID FOR AS SHOULDER GRAVEL. ASPHALT DRIVES SHALL HAVE MILL JOINT FOR TRANSITION. MILLED TRANSITIONS OF ASPHALT DRIVES SHALL BE INCLUDED IN PREP COST. REMOVAL OF CONCRETE DRIVES WILL BE PAID BY PREP COST. ALL TRAFFIC CONTROL, MOBILIZATION/DEMobilIZATION, AND ANY INCIDENTALS NOT SPECIFIED AS LINE ITEMS, SHALL BE INCLUDED IN PREP COST. (0.89 MILES)

**CC 14C CRABAPPLE LN (FORREST LAKES DR – END) MILL 2" AND PAVE 2"** BEGIN ON NORTHEAST EDGELINE AT FORREST LAKES DR AND END AT CUL-DE-SAC. INCLUDE RADIUS AND TAPERS WITH BUTT JOINTS FOR SMOOTH TRANSITION.

MILL ASPHALT IN FRONT OF CONCRETE DRIVES FOR SMOOTH TRANSITION, ASPHALT DRIVES SHALL HAVE MILLED TRANSITIONS AND WILL BE INCLUDED IN PREP COST. REMOVE EXCESS ASPHALT FROM DRIVEWAYS, MATCH DRIVEWAYS TO NEW ASPHALT. ALL MAILBOXES AND DRIVEWAYS SHALL HAVE MINIMUM 2 FOOT BUMP OUT. ADD 53 LIMESTONE FOR DRIVEWAYS IF NEEDED AND APPLY GRAVEL FOR SHOULDERS. IF ROAD HAS DETERIORATED AND NEEDS TO BE MILLED MORE THAN 2 INCHES, A FIELD DIRECTIVE/CHANGE ORDER MAY BE NEEDED FOR EXTRA MILLING.

BEFORE ADJOINING PAVEMENT IS PLACED, LONGITUDINAL JOINT SHALL HAVE JOINT SEAL/ADHESIVE APPLIED. ALL MAILBOXES AND DRIVEWAYS SHALL HAVE MINIMUM 2 FOOT BUMP OUT. ALL LOOSE DEBRIS AT DRIVEWAYS SHALL BE REMOVED. ALL DEBRIS GENERATED THROUGH THE CONSTRUCTION

PROCESS, SHALL BE REMOVED AT COMPLETION OF PAVING. +/- 2 FOOT GRAVEL SHOULDERS SHALL BE ADDED AS WELL AS LIMESTONE FOR GRAVEL DRIVEWAY TAPERS. PERMANENT PAVEMENT MARKING MUST BEING APPLIED NO LATER THAN 14 DAYS AFTER PAVEMENT PLACEMENT. LIMESTONE FOR DRIVEWAY TAPERS WILL BE PAID FOR AS SHOULDER GRAVEL. ASPHALT DRIVES SHALL HAVE MILL JOINT FOR TRANSITION. MILLED TRANSITIONS OF ASPHALT DRIVES SHALL BE INCLUDED IN PREP COST. REMOVAL OF CONCRETE DRIVES WILL BE PAID BY PREP COST. ALL TRAFFIC CONTROL, MOBILIZATION/DEMobilIZATION, AND ANY INCIDENTALS NOT SPECIFIED AS LINE ITEMS, SHALL BE INCLUDED IN PREP COST. (0.08 MILES)

**CC 14D REDWOOD LN (FORREST LAKES DR – END) MILL 2” AND PAVE 2”** BEGIN ON EAST EDGELINE AT FORREST LAKES DR AND END AT CUL-DE-SAC. INCLUDE RADIUS AND TAPERS WITH BUTT JOINTS FOR SMOOTH TRANSITION

MILL ASPHALT IN FRONT OF CONCRETE DRIVES FOR SMOOTH TRANSITION, ASPHALT DRIVES SHALL HAVE MILLED TRANSITIONS AND WILL BE INCLUDED IN PREP COST. REMOVE EXCESS ASPHALT FROM DRIVEWAYS, MATCH DRIVEWAYS TO NEW ASPHALT. ALL MAILBOXES AND DRIVEWAYS SHALL HAVE MINIMUM 2 FOOT BUMP OUT. ADD 53 LIMESTONE FOR DRIVEWAYS IF NEEDED AND APPLY GRAVEL FOR SHOULDERS. IF ROAD HAS DETERIORATED AND NEEDS TO BE MILLED MORE THAN 2 INCHES, A FIELD DIRECTIVE/CHANGE ORDER MAY BE NEEDED FOR EXTRA MILLING.

BEFORE ADJOINING PAVEMENT IS PLACED, LONGITUDINAL JOINT SHALL HAVE JOINT SEAL/ADHESIVE APPLIED. ALL MAILBOXES AND DRIVEWAYS SHALL HAVE MINIMUM 2 FOOT BUMP OUT. ALL LOOSE DEBRIS AT DRIVEWAYS SHALL BE REMOVED. ALL DEBRIS GENERATED THROUGH THE CONSTRUCTION PROCESS, SHALL BE REMOVED AT COMPLETION OF PAVING. +/- 2 FOOT GRAVEL SHOULDERS SHALL BE ADDED AS WELL AS LIMESTONE FOR GRAVEL DRIVEWAY TAPERS. PERMANENT PAVEMENT MARKING MUST BEING APPLIED NO LATER THAN 14 DAYS AFTER PAVEMENT PLACEMENT. LIMESTONE FOR DRIVEWAY TAPERS WILL BE PAID FOR AS SHOULDER GRAVEL. ASPHALT DRIVES SHALL HAVE MILL JOINT FOR TRANSITION. MILLED TRANSITIONS OF ASPHALT DRIVES SHALL BE INCLUDED IN PREP COST. REMOVAL OF CONCRETE DRIVES WILL BE PAID BY PREP COST. ALL TRAFFIC CONTROL, MOBILIZATION/DEMobilIZATION, AND ANY INCIDENTALS NOT SPECIFIED AS LINE ITEMS, SHALL BE INCLUDED IN PREP COST. (0.06 MILES)

**CC 14E JUNIPER LN (FORREST LAKES DR – END) MILL 2” AND PAVE 2”** BEGIN ON WEST EDGELINE OF FORREST LAKES DR AND END AT CUL-DE-SAC. INCLUDE RADIUS AND TAPER FOR SMOOTH TRANSITION. REMOVE ALL ORGANICS IN CUL-DE-SAC WHICH INCLUDES TREES AND TOPSIL. EXCAVATE 6 INCHES BELOW PAVEMENT, PLACE NO 53 AGGREGATE, THE REST SHALL BE HOT MIX ASPHALT. ALL ORGANICS REMOVED SHALL BE INCLUDED IN PREP COST.

MILL ASPHALT IN FRONT OF CONCRETE DRIVES FOR SMOOTH TRANSITION, ASPHALT DRIVES SHALL HAVE MILLED TRANSITIONS AND WILL BE INCLUDED IN PREP COST. REMOVE EXCESS ASPHALT FROM DRIVEWAYS, MATCH DRIVEWAYS TO NEW ASPHALT. ALL MAILBOXES AND DRIVEWAYS SHALL HAVE MINIMUM 2 FOOT BUMP OUT. ADD 53 LIMESTONE FOR DRIVEWAYS IF NEEDED AND APPLY GRAVEL FOR SHOULDERS. IF ROAD HAS DETERIORATED AND NEEDS TO BE MILLED MORE THAN 2 INCHES, A FIELD DIRECTIVE/CHANGE ORDER MAY BE NEEDED FOR EXTRA MILLING.

BEFORE ADJOINING PAVEMENT IS PLACED, LONGITUDINAL JOINT SHALL HAVE JOINT SEAL/ADHESIVE APPLIED. ALL MAILBOXES AND DRIVEWAYS SHALL HAVE MINIMUM 2 FOOT BUMP OUT. ALL LOOSE DEBRIS AT DRIVEWAYS SHALL BE REMOVED. ALL DEBRIS GENERATED THROUGH THE CONSTRUCTION PROCESS, SHALL BE REMOVED AT COMPLETION OF PAVING. +/- 2 FOOT GRAVEL SHOULDERS SHALL BE ADDED AS WELL AS LIMESTONE FOR GRAVEL DRIVEWAY TAPERS. PERMANENT PAVEMENT MARKING MUST BEING APPLIED NO LATER THAN 14 DAYS AFTER PAVEMENT PLACEMENT. LIMESTONE FOR DRIVEWAY TAPERS WILL BE PAID FOR AS SHOULDER GRAVEL. ASPHALT DRIVES SHALL HAVE MILL JOINT FOR TRANSITION. MILLED TRANSITIONS OF ASPHALT DRIVES SHALL BE INCLUDED IN PREP COST. REMOVAL OF CONCRETE DRIVES WILL BE PAID BY PREP COST. ALL TRAFFIC CONTROL, MOBILIZATION/DEMobilIZATION, AND ANY INCIDENTALS NOT SPECIFIED AS LINE ITEMS, SHALL BE INCLUDED IN PREP COST. (0.06 MILES)

**CC 14F CYPRESS LN (FORREST LAKES DR – END) MILL 2” AND PAVE 2”** BEGIN ON EAST EDGELINE AT FORREST LAKES DR AND END AT CUL-DE-SAC. INCLUDE RADIUS AND TAPERS WITH BUTT JOINTS FOR SMOOTH TRANSITION .

MILL ASPHALT IN FRONT OF CONCRETE DRIVES FOR SMOOTH TRANSITION, ASPHALT DRIVES SHALL HAVE MILLED TRANSITIONS AND WILL BE INCLUDED IN PREP COST. REMOVE EXCESS ASPHALT FROM DRIVEWAYS, MATCH DRIVEWAYS TO NEW ASPHALT. ALL MAILBOXES AND DRIVEWAYS SHALL HAVE MINIMUM 2 FOOT BUMP OUT. ADD 53 LIMESTONE FOR DRIVEWAYS IF NEEDED AND APPLY GRAVEL FOR SHOULDERS. IF ROAD HAS DETERIORATED AND NEEDS TO BE MILLED MORE THAN 2 INCHES, A FIELD DIRECTIVE/CHANGE ORDER MAY BE NEEDED FOR EXTRA MILLING.

BEFORE ADJOINING PAVEMENT IS PLACED, LONGITUDINAL JOINT SHALL HAVE JOINT SEAL/ADHESIVE APPLIED. ALL MAILBOXES AND DRIVEWAYS SHALL HAVE MINIMUM 2 FOOT BUMP OUT. ALL LOOSE DEBRIS AT DRIVEWAYS SHALL BE REMOVED. ALL DEBRIS GENERATED THROUGH THE CONSTRUCTION PROCESS, SHALL BE REMOVED AT COMPLETION OF PAVING. +/- 2 FOOT GRAVEL SHOULDERS SHALL BE ADDED AS WELL AS LIMESTONE FOR GRAVEL DRIVEWAY TAPERS. PERMANENT PAVEMENT MARKING MUST BEING APPLIED NO LATER THAN 14 DAYS AFTER PAVEMENT PLACEMENT. LIMESTONE FOR DRIVEWAY TAPERS WILL BE PAID FOR AS SHOULDER GRAVEL. ASPHALT DRIVES SHALL HAVE MILL JOINT FOR TRANSITION. MILLED TRANSITIONS OF ASPHALT DRIVES SHALL BE INCLUDED IN PREP COST. REMOVAL OF CONCRETE DRIVES WILL BE PAID BY PREP COST. ALL TRAFFIC CONTROL, MOBILIZATION/DEMobilIZATION, AND ANY INCIDENTALS NOT SPECIFIED AS LINE ITEMS, SHALL BE INCLUDED IN PREP COST. (0.04 MILES)

**CC 14G ASPEN LN (FORREST LAKES DR – END) MILL 2” AND PAVE 2”** BEGIN ON EAST EDGELINE AT FORREST LAKES DR AND END AT CUL-DE-SAC. INCLUDE RADIUS AND TAPERS WITH BUTT JOINTS FOR SMOOTH TRANSITION.

MILL ASPHALT IN FRONT OF CONCRETE DRIVES FOR SMOOTH TRANSITION, ASPHALT DRIVES SHALL HAVE MILLED TRANSITIONS AND WILL BE INCLUDED IN PREP COST. REMOVE EXCESS ASPHALT FROM DRIVEWAYS, MATCH DRIVEWAYS TO NEW ASPHALT. ALL MAILBOXES AND DRIVEWAYS SHALL HAVE MINIMUM 2 FOOT BUMP OUT. ADD 53 LIMESTONE FOR DRIVEWAYS IF NEEDED AND APPLY GRAVEL

FOR SHOULDERS. IF ROAD HAS DETERIORATED AND NEEDS TO BE MILLED MORE THAN 2 INCHES, A FIELD DIRECTIVE/CHANGE ORDER MAY BE NEEDED FOR EXTRA MILLING.

BEFORE ADJOINING PAVEMENT IS PLACED, LONGITUDINAL JOINT SHALL HAVE JOINT SEAL/ADHESIVE APPLIED. ALL MAILBOXES AND DRIVEWAYS SHALL HAVE MINIMUM 2 FOOT BUMP OUT. ALL LOOSE DEBRIS AT DRIVEWAYS SHALL BE REMOVED. ALL DEBRIS GENERATED THROUGH THE CONSTRUCTION PROCESS, SHALL BE REMOVED AT COMPLETION OF PAVING. +/- 2 FOOT GRAVEL SHOULDERS SHALL BE ADDED AS WELL AS LIMESTONE FOR GRAVEL DRIVEWAY TAPERS. PERMANENT PAVEMENT MARKING MUST BEING APPLIED NO LATER THAN 14 DAYS AFTER PAVEMENT PLACEMENT. LIMESTONE FOR DRIVEWAY TAPERS WILL BE PAID FOR AS SHOULDER GRAVEL. ASPHALT DRIVES SHALL HAVE MILL JOINT FOR TRANSITION. MILLED TRANSITIONS OF ASPHALT DRIVES SHALL BE INCLUDED IN PREP COST. REMOVAL OF CONCRETE DRIVES WILL BE PAID BY PREP COST. ALL TRAFFIC CONTROL, MOBILIZATION/DEMobilIZATION, AND ANY INCIDENTALS NOT SPECIFIED AS LINE ITEMS, SHALL BE INCLUDED IN PREP COST. (0.05 MILES)

**CC 14H BUTTERNUT DR (FORREST LAKES DR – END) MILL 2” AND PAVE 2”** BEGIN ON EAST EDGELINE AT FORREST LAKES DR AND END AT CUL-DE-SAC. INCLUDE RADIUS AND TAPERS WITH BUTT JOINTS FOR SMOOTH TRANSITION.

MILL ASPHALT IN FRONT OF CONCRETE DRIVES FOR SMOOTH TRANSITION, ASPHALT DRIVES SHALL HAVE MILLED TRANSITIONS AND WILL BE INCLUDED IN PREP COST. REMOVE EXCESS ASPHALT FROM DRIVEWAYS, MATCH DRIVEWAYS TO NEW ASPHALT. ALL MAILBOXES AND DRIVEWAYS SHALL HAVE MINIMUM 2 FOOT BUMP OUT. ADD 53 LIMESTONE FOR DRIVEWAYS IF NEEDED AND APPLY GRAVEL FOR SHOULDERS. IF ROAD HAS DETERIORATED AND NEEDS TO BE MILLED MORE THAN 2 INCHES, A FIELD DIRECTIVE/CHANGE ORDER MAY BE NEEDED FOR EXTRA MILLING.

BEFORE ADJOINING PAVEMENT IS PLACED, LONGITUDINAL JOINT SHALL HAVE JOINT SEAL/ADHESIVE APPLIED. ALL MAILBOXES AND DRIVEWAYS SHALL HAVE MINIMUM 2 FOOT BUMP OUT. ALL LOOSE DEBRIS AT DRIVEWAYS SHALL BE REMOVED. ALL DEBRIS GENERATED THROUGH THE CONSTRUCTION PROCESS, SHALL BE REMOVED AT COMPLETION OF PAVING. +/- 2 FOOT GRAVEL SHOULDERS SHALL BE ADDED AS WELL AS LIMESTONE FOR GRAVEL DRIVEWAY TAPERS. PERMANENT PAVEMENT MARKING MUST BEING APPLIED NO LATER THAN 14 DAYS AFTER PAVEMENT PLACEMENT. LIMESTONE FOR DRIVEWAY TAPERS WILL BE PAID FOR AS SHOULDER GRAVEL. ASPHALT DRIVES SHALL HAVE MILL JOINT FOR TRANSITION. MILLED TRANSITIONS OF ASPHALT DRIVES SHALL BE INCLUDED IN PREP COST. REMOVAL OF CONCRETE DRIVES WILL BE PAID BY PREP COST. ALL TRAFFIC CONTROL, MOBILIZATION/DEMobilIZATION, AND ANY INCIDENTALS NOT SPECIFIED AS LINE ITEMS, SHALL BE INCLUDED IN PREP COST. (0.11 MILES)

**CC 15A TIMBER RIDGE DR (COUNTY ROAD 19 – BEECH GROVE DR) MILL 2” AND PAVE 2”** BEGIN ON EAST EDGELINE OF COUNTY ROAD 19 AND END AT WEST EDGELINE OF BEECH GROVE DR. INCLUDE RADIUS AND TAPERS WITH BUTT JOINTS FOR SMOOTH TRANSITION.

MILL ASPHALT IN FRONT OF CONCRETE DRIVES FOR SMOOTH TRANSITION, ASPHALT DRIVES SHALL HAVE MILLED TRANSITIONS AND WILL BE INCLUDED IN PREP COST. REMOVE EXCESS ASPHALT FROM DRIVEWAYS, MATCH DRIVEWAYS TO NEW ASPHALT. ALL MAILBOXES AND DRIVEWAYS SHALL HAVE MINIMUM 2 FOOT BUMP OUT. ADD 53 LIMESTONE FOR DRIVEWAYS IF NEEDED AND APPLY GRAVEL

FOR SHOULDERS. IF ROAD HAS DETERIORATED AND NEEDS TO BE MILLED MORE THAN 2 INCHES, A FIELD DIRECTIVE/CHANGE ORDER MAY BE NEEDED FOR EXTRA MILLING.

BEFORE ADJOINING PAVEMENT IS PLACED, LONGITUDINAL JOINT SHALL HAVE JOINT SEAL/ADHESIVE APPLIED. ALL MAILBOXES AND DRIVEWAYS SHALL HAVE MINIMUM 2 FOOT BUMP OUT. ALL LOOSE DEBRIS AT DRIVEWAYS SHALL BE REMOVED. ALL DEBRIS GENERATED THROUGH THE CONSTRUCTION PROCESS, SHALL BE REMOVED AT COMPLETION OF PAVING. +/- 2 FOOT GRAVEL SHOULDERS SHALL BE ADDED AS WELL AS LIMESTONE FOR GRAVEL DRIVEWAY TAPERS. PERMANENT PAVEMENT MARKING MUST BEING APPLIED NO LATER THAN 14 DAYS AFTER PAVEMENT PLACEMENT. LIMESTONE FOR DRIVEWAY TAPERS WILL BE PAID FOR AS SHOULDER GRAVEL. ASPHALT DRIVES SHALL HAVE MILL JOINT FOR TRANSITION. MILLED TRANSITIONS OF ASPHALT DRIVES SHALL BE INCLUDED IN PREP COST. REMOVAL OF CONCRETE DRIVES WILL BE PAID BY PREP COST. ALL TRAFFIC CONTROL, MOBILIZATION/DEMobilIZATION, AND ANY INCIDENTALS NOT SPECIFIED AS LINE ITEMS, SHALL BE INCLUDED IN PREP COST. (0.15 MILES)

**CC 15B RED OAK CT (TIMBER RIDGE DR - END) MILL 2" AND PAVE 2"** BEGIN ON SOUTH EDGELINE OF TIMBER RIDGE DR AND END AT CUL-DE-SAC. INCLUDE RADIUS AND TAPERS WITH BUTT JOINTS FOR SMOOTH TRANSITION.

MILL ASPHALT IN FRONT OF CONCRETE DRIVES FOR SMOOTH TRANSITION, ASPHALT DRIVES SHALL HAVE MILLED TRANSITIONS AND WILL BE INCLUDED IN PREP COST. REMOVE EXCESS ASPHALT FROM DRIVEWAYS, MATCH DRIVEWAYS TO NEW ASPHALT. ALL MAILBOXES AND DRIVEWAYS SHALL HAVE MINIMUM 2 FOOT BUMP OUT. ADD 53 LIMESTONE FOR DRIVEWAYS IF NEEDED AND APPLY GRAVEL FOR SHOULDERS. IF ROAD HAS DETERIORATED AND NEEDS TO BE MILLED MORE THAN 2 INCHES, A FIELD DIRECTIVE/CHANGE ORDER MAY BE NEEDED FOR EXTRA MILLING.

BEFORE ADJOINING PAVEMENT IS PLACED, LONGITUDINAL JOINT SHALL HAVE JOINT SEAL/ADHESIVE APPLIED. ALL MAILBOXES AND DRIVEWAYS SHALL HAVE MINIMUM 2 FOOT BUMP OUT. ALL LOOSE DEBRIS AT DRIVEWAYS SHALL BE REMOVED. ALL DEBRIS GENERATED THROUGH THE CONSTRUCTION PROCESS, SHALL BE REMOVED AT COMPLETION OF PAVING. +/- 2 FOOT GRAVEL SHOULDERS SHALL BE ADDED AS WELL AS LIMESTONE FOR GRAVEL DRIVEWAY TAPERS. PERMANENT PAVEMENT MARKING MUST BEING APPLIED NO LATER THAN 14 DAYS AFTER PAVEMENT PLACEMENT. LIMESTONE FOR DRIVEWAY TAPERS WILL BE PAID FOR AS SHOULDER GRAVEL. ASPHALT DRIVES SHALL HAVE MILL JOINT FOR TRANSITION. MILLED TRANSITIONS OF ASPHALT DRIVES SHALL BE INCLUDED IN PREP COST. REMOVAL OF CONCRETE DRIVES WILL BE PAID BY PREP COST. ALL TRAFFIC CONTROL, MOBILIZATION/DEMobilIZATION, AND ANY INCIDENTALS NOT SPECIFIED AS LINE ITEMS, SHALL BE INCLUDED IN PREP COST. (0.06 MILES)

**CC 15C SUGAR MAPLE CT (TIMBER RIDGE DR - END) MILL 2" AND PAVE 2"** BEGIN ON NORTH EDGELINE OF TIMBER RIDGE DR AND END AT CUL-DE-SAC. INCLUDE RADIUS AND TAPERS WITH BUTT JOINTS FOR SMOOTH TRANSITION.

MILL ASPHALT IN FRONT OF CONCRETE DRIVES FOR SMOOTH TRANSITION, ASPHALT DRIVES SHALL HAVE MILLED TRANSITIONS AND WILL BE INCLUDED IN PREP COST. REMOVE EXCESS ASPHALT FROM DRIVEWAYS, MATCH DRIVEWAYS TO NEW ASPHALT. ALL MAILBOXES AND DRIVEWAYS SHALL HAVE

MINIMUM 2 FOOT BUMP OUT. ADD 53 LIMESTONE FOR DRIVEWAYS IF NEEDED AND APPLY GRAVEL FOR SHOULDERS. IF ROAD HAS DETERIORATED AND NEEDS TO BE MILLED MORE THAN 2 INCHES, A FIELD DIRECTIVE/CHANGE ORDER MAY BE NEEDED FOR EXTRA MILLING.

BEFORE ADJOINING PAVEMENT IS PLACED, LONGITUDINAL JOINT SHALL HAVE JOINT SEAL/ADHESIVE APPLIED. ALL MAILBOXES AND DRIVEWAYS SHALL HAVE MINIMUM 2 FOOT BUMP OUT. ALL LOOSE DEBRIS AT DRIVEWAYS SHALL BE REMOVED. ALL DEBRIS GENERATED THROUGH THE CONSTRUCTION PROCESS, SHALL BE REMOVED AT COMPLETION OF PAVING. +/- 2 FOOT GRAVEL SHOULDERS SHALL BE ADDED AS WELL AS LIMESTONE FOR GRAVEL DRIVEWAY TAPERS. PERMANENT PAVEMENT MARKING MUST BEING APPLIED NO LATER THAN 14 DAYS AFTER PAVEMENT PLACEMENT. LIMESTONE FOR DRIVEWAY TAPERS WILL BE PAID FOR AS SHOULDER GRAVEL. ASPHALT DRIVES SHALL HAVE MILL JOINT FOR TRANSITION. MILLED TRANSITIONS OF ASPHALT DRIVES SHALL BE INCLUDED IN PREP COST. REMOVAL OF CONCRETE DRIVES WILL BE PAID BY PREP COST. ALL TRAFFIC CONTROL, MOBILIZATION/DEMobilIZATION, AND ANY INCIDENTALS NOT SPECIFIED AS LINE ITEMS, SHALL BE INCLUDED IN PREP COST. (0.08 MILES)

**CC 15D BEECH GROVE DR (END - END) MILL 2" AND PAVE 2"** BEGIN ON EAST EDGELINE OF TIMBER RIDGE DR AND END AT BOTH CUL-DE-SACS. INCLUDE RADIUS AND TAPERS WITH BUTT JOINTS FOR SMOOTH TRANSITION.

MILL ASPHALT IN FRONT OF CONCRETE DRIVES FOR SMOOTH TRANSITION, ASPHALT DRIVES SHALL HAVE MILLED TRANSITIONS AND WILL BE INCLUDED IN PREP COST. REMOVE EXCESS ASPHALT FROM DRIVEWAYS, MATCH DRIVEWAYS TO NEW ASPHALT. ALL MAILBOXES AND DRIVEWAYS SHALL HAVE MINIMUM 2 FOOT BUMP OUT. ADD 53 LIMESTONE FOR DRIVEWAYS IF NEEDED AND APPLY GRAVEL FOR SHOULDERS. IF ROAD HAS DETERIORATED AND NEEDS TO BE MILLED MORE THAN 2 INCHES, A FIELD DIRECTIVE/CHANGE ORDER MAY BE NEEDED FOR EXTRA MILLING.

BEFORE ADJOINING PAVEMENT IS PLACED, LONGITUDINAL JOINT SHALL HAVE JOINT SEAL/ADHESIVE APPLIED. ALL MAILBOXES AND DRIVEWAYS SHALL HAVE MINIMUM 2 FOOT BUMP OUT. ALL LOOSE DEBRIS AT DRIVEWAYS SHALL BE REMOVED. ALL DEBRIS GENERATED THROUGH THE CONSTRUCTION PROCESS, SHALL BE REMOVED AT COMPLETION OF PAVING. +/- 2 FOOT GRAVEL SHOULDERS SHALL BE ADDED AS WELL AS LIMESTONE FOR GRAVEL DRIVEWAY TAPERS. PERMANENT PAVEMENT MARKING MUST BEING APPLIED NO LATER THAN 14 DAYS AFTER PAVEMENT PLACEMENT. LIMESTONE FOR DRIVEWAY TAPERS WILL BE PAID FOR AS SHOULDER GRAVEL. ASPHALT DRIVES SHALL HAVE MILL JOINT FOR TRANSITION. MILLED TRANSITIONS OF ASPHALT DRIVES SHALL BE INCLUDED IN PREP COST. REMOVAL OF CONCRETE DRIVES WILL BE PAID BY PREP COST. ALL TRAFFIC CONTROL, MOBILIZATION/DEMobilIZATION, AND ANY INCIDENTALS NOT SPECIFIED AS LINE ITEMS, SHALL BE INCLUDED IN PREP COST. (0.17 MILES)

**EC 1 BRIDGE DECK RESURFACE #149 WITH MEMBRANE (COUNTY ROAD 28 BETWEEN COUNTY ROAD 13 – COUNTY ROAD 11) MILL 2" AND PAVE 2"**

WHEN BRIDGE DECK IS STRIPPED AND CONCRETE BOX BEAMS ARE EXPOSED, THE STRUCTURE MUST BE INSPECTED AND VARIFIED BY BRIDGE ENGINEER BEFORE RESURFACING.

PER TP33 BRIDGE DECK RESURFACING SPECIFICATIONS;

1. MEMBRANE SHALL NOT BE APPLIED TO BRIDGE DECKS 24 HOURS PRIOR TO PAVING



2. Resurfacing the bridge deck to fascia including approach tapers as directed with the HMA surface material specified.
3. A leveling course of asphalt may be applied to bridge deck prior to final paving, but shall not exceed 1.5"
4. Saw cutting a 1/8" thick transverse joint the width of the deck at each abutment and pier and filling the saw cut with self-leveling caulk. Saw cut must be dry and clean of debris before caulk is applied.

Monuments are the responsibility of the contractor on all segments awarded within the Paving Contract. Maintaining location and preservation, visibility, and adjusting to new grade shall be the responsibility of the contractor. If a monument will need to be replaced due to change in profile, where a riser will not suffice, or, at the direction of Owner, a line item will be supplied in the bid tab to accommodate the replacement item.

Existing monuments shall not be disturbed unless directed by Engineer. Any monument disturbed through the construction process, shall be replaced at the Contractors expense including cost of monument

**EC 2 CLAYTON ST (SHAFFER AVE – CUL-DE-SAC) MILL 2" AND PAVE 2"** BEGIN ON NORTH EDGELINE OF SHAFFER AVE AND END AT CUL-DE-SAC. INCLUDE RADIUS AND TAPERS WITH BUTT JOINTS FOR SMOOTH TRANSITION.

MILL ASPHALT IN FRONT OF CONCRETE DRIVES FOR SMOOTH TRANSITION, ASPHALT DRIVES SHALL HAVE MILLED TRANSITIONS AND WILL BE INCLUDED IN PREP COST. REMOVE EXCESS ASPHALT FROM DRIVEWAYS, MATCH DRIVEWAYS TO NEW ASPHALT. ALL MAILBOXES AND DRIVEWAYS SHALL HAVE MINIMUM 2 FOOT BUMP OUT. ADD 53 LIMESTONE FOR DRIVEWAYS IF NEEDED AND APPLY GRAVEL FOR SHOULDERS. IF ROAD HAS DETERIORATED AND NEEDS TO BE MILLED MORE THAN 2 INCHES, A FIELD DIRECTIVE/CHANGE ORDER MAY BE NEEDED FOR EXTRA MILLING.

BEFORE ADJOINING PAVEMENT IS PLACED, LONGITUDINAL JOINT SHALL HAVE JOINT SEAL/ADHESIVE APPLIED. ALL MAILBOXES AND DRIVEWAYS SHALL HAVE MINIMUM 2 FOOT BUMP OUT. ALL LOOSE DEBRIS AT DRIVEWAYS SHALL BE REMOVED. ALL DEBRIS GENERATED THROUGH THE CONSTRUCTION PROCESS, SHALL BE REMOVED AT COMPLETION OF PAVING. +/- 2 FOOT GRAVEL SHOULDERS SHALL BE ADDED AS WELL AS LIMESTONE FOR GRAVEL DRIVEWAY TAPERS. PERMANENT PAVEMENT MARKING MUST BEING APPLIED NO LATER THAN 14 DAYS AFTER PAVEMENT PLACEMENT. LIMESTONE FOR DRIVEWAY TAPERS WILL BE PAID FOR AS SHOULDER GRAVEL. ASPHALT DRIVES SHALL HAVE MILL JOINT FOR TRANSITION. MILLED TRANSITIONS OF ASPHALT DRIVES SHALL BE INCLUDED IN PREP COST. REMOVAL OF CONCRETE DRIVES WILL BE PAID BY PREP COST. ALL TRAFFIC CONTROL, MOBILIZATION/DEMobilIZATION, AND ANY INCIDENTALS NOT SPECIFIED AS LINE ITEMS, SHALL BE INCLUDED IN PREP COST. (0.08 MILES)

**EC 3 BRIDGE DECK RESURFACE #183 (COUNTY ROAD 43 BETWEEN US 20 AND COUNTY ROAD 16) MILL 2" AND PAVE 2"**

WHEN BRIDGE DECK IS STRIPPED AND TIMBER BEAMS ARE EXPOSED, THE STRUCTURE MUST BE INSPECTED AND VARIFIED BY BRIDGE ENGINEER BEFORE RESURFACING.

PER TP33 BRIDGE DECK RESURFACING SPECIFICATIONS;

1. Resurfacing the bridge deck to facia including approach tapers as directed with the HMA surface material specified.
2. A leveling course of asphalt may be applied to bridge deck prior to final paving, but shall not exceed 1.5"
3. Saw cutting a 1/8" thick transverse joint the width of the deck at each abutment and pier and filling the saw cut with self-leveling caulk. Saw cut must be dry and clean of debris before caulk is applied.

Monuments are the responsibility of the contractor on all segments awarded within the Paving Contract. Maintaining location and preservation, visibility, and adjusting to new grade shall be the responsibility of the contractor. If a monument will need to be replaced due to change in profile, where a riser will not suffice, or, at the direction of Owner, a line item will be supplied in the bid tab to accommodate the replacement item.

Existing monuments shall not be disturbed unless directed by Engineer. Any monument disturbed through the construction process, shall be replaced at the Contractors expense including cost of monument

**EC 4 BRIDGE DECK RESURFACE #206 WITH MEMBRANE (COUNTY ROAD 33 BETWEEN COUNTY ROAD 38 AND COUNTY ROAD 40) MILL 2" AND PAVE 2"**

WHEN BRIDGE DECK IS STRIPPED AND CONCRETE BOX BEAMS ARE EXPOSED, THE STRUCTURE MUST BE INSPECTED AND VARIFIED BY BRIDGE ENGINEER BEFORE RESURFACING.

PER TP33 BRIDGE DECK RESURFACING SPECIFICATIONS;

1. **MEMBRANE SHALL NOT BE APPLIED TO BRIDGE DECKS 24 HOURS PRIOR TO PAVING**
2. Resurfacing the bridge deck to facia including approach tapers as directed with the HMA surface material specified.
3. A leveling course of asphalt may be applied to bridge deck prior to final paving, but shall not exceed 1.5"
4. Saw cutting a 1/8" thick transverse joint the width of the deck at each abutment and pier and filling the saw cut with self-leveling caulk. Saw cut must be dry and clean of debris before caulk is applied.

Monuments are the responsibility of the contractor on all segments awarded within the Paving Contract. Maintaining location and preservation, visibility, and adjusting to new grade shall be the responsibility of the contractor. If a monument will need to be replaced due to change in profile, where a riser will not suffice, or, at the direction of Owner, a line item will be supplied in the bid tab to accommodate the replacement item.

Existing monuments shall not be disturbed unless directed by Engineer. Any monument disturbed through the construction process, shall be replaced at the Contractors expense including cost of monument

### **EC 5 BRIDGE DECK RESURFACE #210 (COUNTY ROAD 31 BETWEEN COUNTY ROAD 138 AND COUNTY ROAD 38) MILL 2" AND PAVE 2"**

WHEN BRIDGE DECK IS STRIPPED AND TIMBER BEAMS ARE EXPOSED, THE STRUCTURE MUST BE INSPECTED AND VARIFIED BY BRIDGE ENGINEER BEFORE RESURFACING.

PER TP33 BRIDGE DECK RESURFACING SPECIFICATIONS;

1. Resurfacing the bridge deck to facia including approach tapers as directed with the HMA surface material specified.
2. A leveling course of asphalt may be applied to bridge deck prior to final paving, but shall not exceed 1.5"
3. Saw cutting a 1/8" thick transverse joint the width of the deck at each abutment and pier and filling the saw cut with self-leveling caulk. Saw cut must be dry and clean of debris before caulk is applied.

Monuments are the responsibility of the contractor on all segments awarded within the Paving Contract. Maintaining location and preservation, visibility, and adjusting to new grade shall be the responsibility of the contractor. If a monument will need to be replaced due to change in profile, where a riser will not suffice, or, at the direction of Owner, a line item will be supplied in the bid tab to accommodate the replacement item.

Existing monuments shall not be disturbed unless directed by Engineer. Any monument disturbed through the construction process, shall be replaced at the Contractors expense including cost of monument

### **EC 6 BRIDGE DECK RESURFACE #351 WITH MEMBRANE (COUNTY ROAD 44 BETWEEN COUNTY ROAD 44 AND COUNTY ROAD 46) MILL 2" AND PAVE 2"**

WHEN BRIDGE DECK IS STRIPPED AND CONCRETE BOX BEAMS ARE EXPOSED, THE STRUCTURE MUST BE INSPECTED AND VARIFIED BY BRIDGE ENGINEER BEFORE RESURFACING.

PER TP33 BRIDGE DECK RESURFACING SPECIFICATIONS;

1. MEMBRANE SHALL NOT BE APPLIED TO BRIDGE DECKS 24 HOURS PRIOR TO PAVING
2. Resurfacing the bridge deck to facia including approach tapers as directed with the HMA

surface material specified.

3. A leveling course of asphalt may be applied to bridge deck prior to final paving, but shall not exceed 1.5"
4. Saw cutting a 1/8" thick transverse joints the width of the deck at each abutment and pier and filling the saw cut with self-leveling caulk. Saw cut must be dry and clean of debris before caulk is applied.

Monuments are the responsibility of the contractor on all segments awarded within the Paving Contract. Maintaining location and preservation, visibility, and adjusting to new grade shall be the responsibility of the contractor. If a monument will need to be replaced due to change in profile, where a riser will not suffice, or, at the direction of Owner, a line item will be supplied in the bid tab to accommodate the replacement item.

Existing monuments shall not be disturbed unless directed by Engineer. Any monument disturbed through the construction process, shall be replaced at the Contractors expense including cost of monument

#### **EC 7 ECL SPEED HUMPS (EAST COUNTY LINE BETWEEN COUNTY ROAD 4 – INTERSTATE 80-90) SPEED HUMPS INSTALL**

SEE PLANS IN SPECIFICATIONS

**ALT 1 COUNTY ROAD 6 (COUNTY ROAD 9 – COUNTY ROAD 11) MILL 2" AND PAVE 2"**. BEGIN AT EAST EDGE OF CR 6 AND CR 11 INTERSECTION, MILL TO WESTBOUND STOPBAR AT CR 6 AND CR 11 INTERSECTION. MILL TO NORTH OF OSOLO ELEMENTRY SCHOOL DRIVEWAY ENTRANCE ON CR 11. MILL TO TRANSITION AT SOUTH MOBIL DRIVEWAY ENTRANCE OF CR 11 SOUTH OF CR 6. MILL TO STOP SIGN ON STRYKER ST, MILL TO STOP SIGN ON BOYLAND, MILL TO STOPBAR ON PARK SIX DR. END AT WESTBOUND STOPBAR AT CR 6 AND CR 9 INTERESCTION. INSTALL DETECTION LOOPS AND DETECTOR HOUSING PER ATTACHED PLAN AT THE CR 6 AND CR 11 INTERSECTION.

BEFORE ADJOINING PAVEMENT IS PLACED, LONGITUDINAL JOINT SHALL HAVE JOINT SEAL/ADHESIVE APPLIED. ALL MAILBOXES AND DRIVEWAYS SHALL HAVE MINIMUM 2 FOOT BUMP OUT. ALL LOOSE DEBRIS AT DRIVEWAYS SHALL BE REMOVED. PAVEMENT IS TO HAVE ALL DISTURBED PAVEMENT MARKINGS REAPPLIED TO PRE-CONSTRUCTION LOCATIONS, AS OUTLINED IN THE INDIANA MUTCD. ALL DEBRIS GENERATED THROUGH THE CONSTRUCTION PROCESS, SHALL BE REMOVED AT COMPLETION OF PAVING. TEMPORARY PAVEMENT MARKINGS SHALL BE APPLIED SAME DAY AS COMPLETED PAVING, WITH PERMANENT PAVEMENT MARKINGS BEING APPLIED NO LATER THAN 14 DAYS AFTER PAVEMENT PLACEMENT. 2 FOOT GRAVEL SHOULDERS SHALL BE ADDED AS WELL AS LIMESTONE FOR GRAVEL DRIVEWAY TAPERS. LIMESTONE FOR DRIVEWAY TAPERS WILL BE PAID FOR AS SHOULDER GRAVEL. ASPHALT DRIVES SHALL HAVE MILL JOINT FOR TRANSITION. MILLED TRANSITIONS OF ASPHALT DRIVES SHALL BE INCLUDED IN PREP COST. 6 +/- MANHOLES WILL BE ENCOUNTERED ON THIS SEGMENT AND ADJUSTMENT MAY VARY. ALL MANHOLES ENCOUNTERED SHALL REMAIN IN PLACE. IF AN EXISTING CASTING IS UNFIT FOR FURTHER USE, A NEW CASTING SHALL BE INSTALLED AND PAID FOR AT THE UNIT PRICE. IF RISERS ARE TO BE USED, NEENAH R-1979 SERIES ADJUSTING RINGS OR APPROVED EQUAL, SHALL BE USED AND PAID FOR BY CONTRACT LINE ITEM, NO MANHOLE SHALL BE HIGHER THAN FINISHED ASPHALT AND SHALL BE RECESSED NO GREATER THAN 1/2 INCH. ALL TRAFFIC CONTROL,

MOBILIZATION/DEMobilIZATION, AND ANY INCIDENTALS NOT SPECIFIED AS LINE ITEMS, SHALL BE INCLUDED IN PREP COST. ALL MEASUREMENTS FOR TAPERS, CROSS STREETS AND INTERSECTIONS WILL BE FIELD VERIFIED BY ENGINEER. IF ANY PARKING LOT OR ACCESS DRIVE IS WITHIN CLOSE PROXIMITY 24" +/- OF ROAD EDGE ESTABLISH NEW JOINT BY MILLING INTO EXISTING ASPHALT.



*Elkhart County*  
**HIGHWAY DEPARTMENT**  
 610 STEURY AVE. GOSHEN, IN 46528  
 PH: 574-534-9394  
 FAX: 574-533-7103  
 WWW.ELKCOHWY.ORG

**PRELIMINARY**  
 THIS DOCUMENT IS RELEASED FOR THE PURPOSE OF INTERIM REVIEW AND IS NOT INTENDED FOR CONSTRUCTION, BIDDING OR PERMIT PURPOSES.

REV	DESCRIPTION	DATE
-	-	-
-	-	-
-	-	-
-	-	-
-	-	-
-	-	-
-	-	-

**EAST COUNTY LINE  
 SPEED HUMPS**

DESIGNED: _____	HORIZONTAL SCALE 1"=50'
CHECKED: _____	VERTICAL SCALE
DRAWN: _____	SHEETS 1 OF 3
CHECKED: _____	PROJECT



*Elkhart County*  
**HIGHWAY DEPARTMENT**  
 610 STEURY AVE, GOSHEN, IN 46528  
 PH: 574-534-9394  
 FAX: 574-533-7103  
 WWW.ELKCOHWY.ORG

**PRELIMINARY**  
 THIS DOCUMENT IS RELEASED FOR THE PURPOSE OF INTERIM REVIEW AND IS NOT INTENDED FOR CONSTRUCTION, BIDDING OR PERMIT PURPOSES.

REV	DESCRIPTION	DATE
-	-	-
-	-	-
-	-	-
-	-	-
-	-	-
-	-	-
-	-	-

**EAST COUNTY LINE  
 SPEED HUMPS**

DESIGNED: _____	HORIZONTAL SCALE 1"=50'
CHECKED: _____	VERTICAL SCALE
DRAWN: _____	SHEETS 2 OF 3
CHECKED: _____	PROJECT



*Elkhart County*  
**HIGHWAY DEPARTMENT**  
 610 STEURY AVE. GOSHEN, IN 46528  
 PH: 574-534-9394  
 FAX: 574-533-7103  
 WWW.ELKCOHWY.ORG

**PRELIMINARY**  
 THIS DOCUMENT IS RELEASED FOR THE PURPOSE OF INTERIM REVIEW AND IS NOT INTENDED FOR CONSTRUCTION, BIDDING OR PERMIT PURPOSES.

REV	DESCRIPTION	DATE
-	-	-
-	-	-
-	-	-
-	-	-
-	-	-
-	-	-
-	-	-

**EAST COUNTY LINE  
 SPEED HUMPS**

DESIGNED: _____
CHECKED: _____
DRAWN: _____
CHECKED: _____

HORIZONTAL SCALE 1"=50'
VERTICAL SCALE
SHEETS 3 OF 3
PROJECT



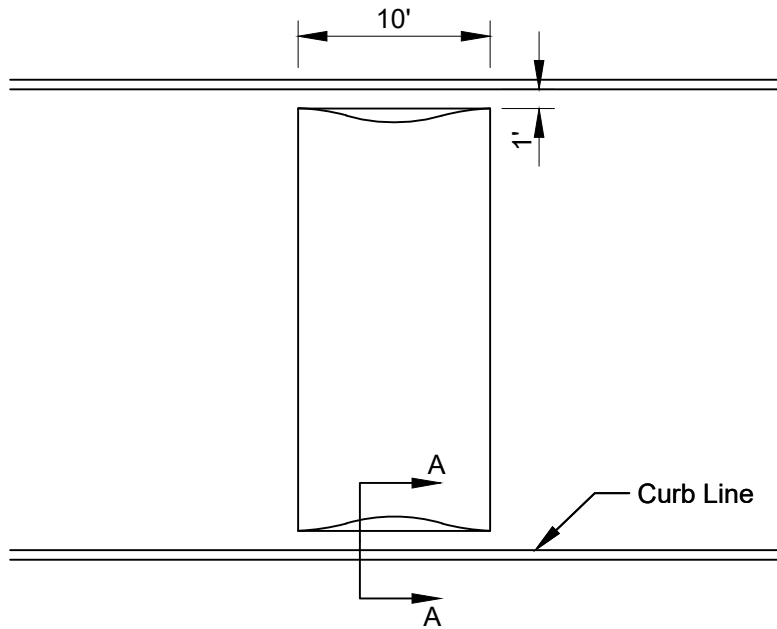

PLAN

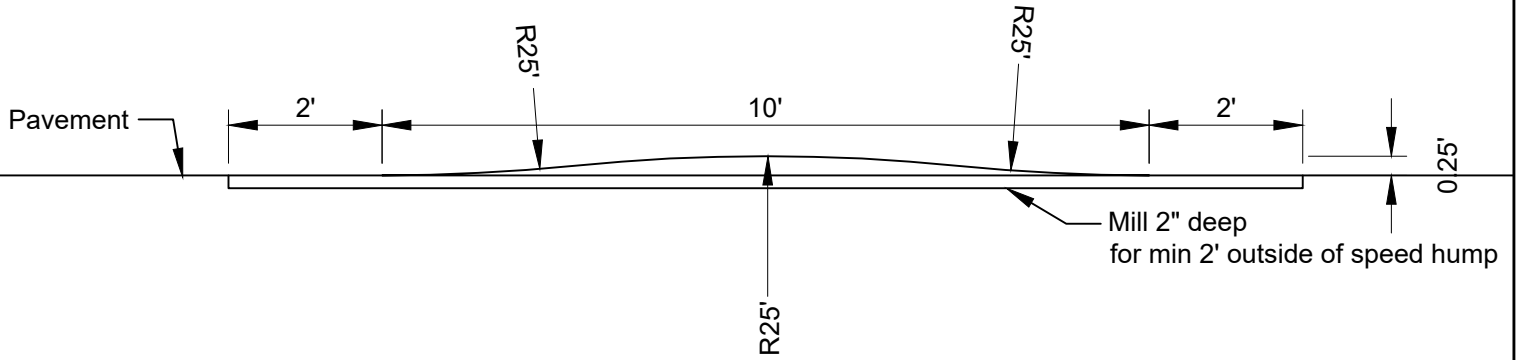

ELEVATION

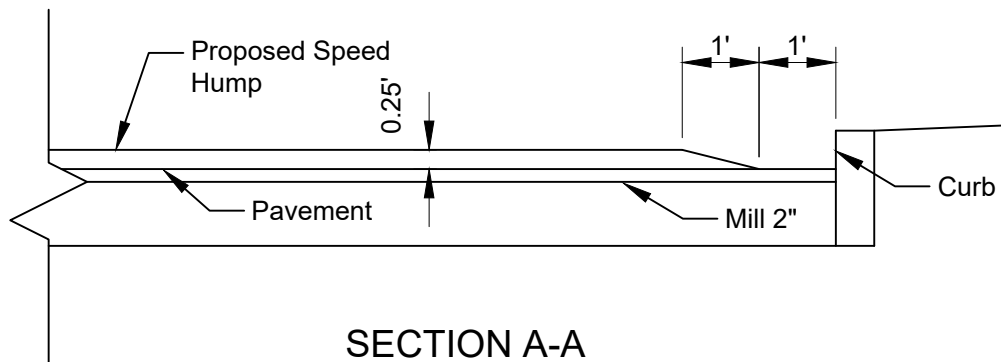

SECTION A-A

NOTES

- Speed humps should be at least 50 ft. from an uncontrolled intersection and at least 200 ft. from a controlled intersection.

*Elkhart County*  
 HIGHWAY DIVISION  
 ENGINEERING SECTION  
 610 STEURY AVE, GOSHEN, IN 46528  
 PH: 574-534-9394  
 FAX: 574-533-7103  
 WWW.ELKCOHWY.ORG

ELKHART COUNTY STREET STANDARDS

SPEED HUMP DETAILS

DESIGNED: _____	DRAWN: _____
CHECKED: _____	CHECKED: _____
HORIZONTAL SCALE	SHEETS
VERTICAL SCALE	PROJECT

Modified from IMUTCD Figure 3B-29 Option A:

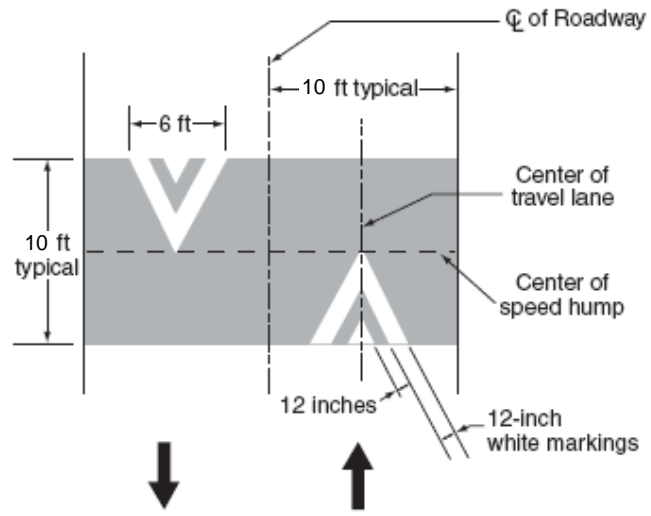



**LEGEND:**

- DETECTION LOOP
- DETECTOR HOUSING

**NOTES:**

1. DETECTOR HOUSINGS SHALL BE REPLACED WITH NEW UNITS AT EXISTING LOCATIONS.
2. ALL WORK SHALL COMPLY WITH ELKHART COUNTY TRAFFIC SIGNAL STANDARDS AND INDOT STANDARD DRAWING E-805-SGLI
3. EACH LANE SHALL HAVE INDEPENDENT LOOP SERIES AND LOOP LEAD-IN WIRING

*Elkhart County*  
**HIGHWAY DEPARTMENT  
 ENGINEERING SECTION**

610 STEURY AVE, GOSHEN, IN 46528  
 PH: 574-533-0538  
 FAX: 574-533-7103  
 WWW.ELKCOHWY.ORG

**2025-1 CCMG PAVING PROGRAM  
 ALT-1: CR 6 FROM CR 9 TO CR 11**

**CR 6 AND CR 11 INTERSECTION:  
 DETECTION LOOP AND HOUSING LAYOUT**

DESIGNED: <u>          VDD          </u>	DRAWN: <u>          VDD          </u>
CHECKED: <u>          VDD          </u>	CHECKED: <u>          VDD          </u>
HORIZONTAL SCALE	SHEETS
VERTICAL SCALE	PROJECT